

Traditional Walnut, Soft Close, Seat & Cover 8081AWSC-SF



Specification

Finish	Walnut (Made of solid wood)
Dimensions	62(h) x 370(w) x 434(d) mm
Weight	2.6kg
Seat Hinge Material	Chrome Plated Zinc Alloy/ Stainless Steel Cover Plate
Hinge Type	Soft close
Hinge Fixing Type	Quick release, Top Fix and Underfix, Secure-Fix QR
Antibacterial Protection	No
Seat Type	Sandwich
UV Protection	-
Max Load Test	150kg
Seat Material	Wood

Spares

Soft Close Hinges (Pair)	SP14430
Secure Fix Hinge Fixing Pack	SP19733
Secure Fix Template	SP19749
Ring Buffer	SP10540
Lid Buffer	SP10537

FAQs

Please see next page

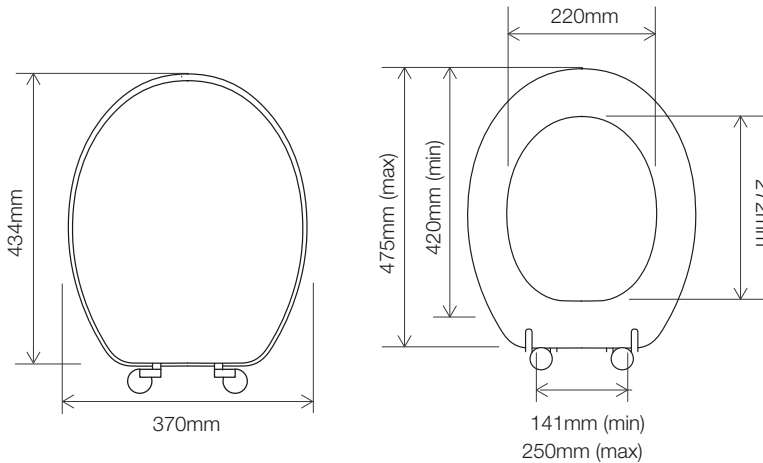

Extra Dimensions

Seat/Lid Front to Back – 434mm
 Seat/Lid Left to Right – 370mm
 Ring Hole Front to Back – 272mm
 Ring Hole Left to Right – 220mm
 Seat Overall Thickness – 20mm
 Min/Max Adjustment for Fixings –
 141/250, 420/475mm

Key Features + Benefits



5
Years
Guarantee



Quick
Release



Top Fix
Hinges



Soft Close
Seat

Secure-Fix **QR**

Certifications + Approvals

Roper Rhodes

Brassmill Lane Trading Estate, Bath, BA1 3JF. Technical Support – Tel: 01225 303 900 Email: sales@roperrhodes.co.uk

All information on the data sheet is correct at the time of publication. All measurements are approximate and subject to standard tolerances.

Technical Data Sheet | Toilet Seats

www.instinctproducts.co.uk

Traditional Walnut, Soft Close, Seat & Cover 8081AWSC-SF

FAQs

Q – What's the maximum test load of the seat?

A – 150kg.

Q – What are the fixings made from?

A – Chrome plated zinc alloy/stainless steel cover plate.

Q – What is the substrate?

A – Solid American walnut.