

## Technical Data Sheet | Thermostatic Radiator Valve (TRV)

www.instinctproducts.co.uk

### 15mm Straight Thermostatic Radiator Valve (Twin Pack) 15PACKSCP.1



#### Specification

Finish	Chrome Plated
Dimensions	124(h) x 85(w) x 48(d) mm
Weight	0.273kg
Max Flow Temperature	110°C
Max. Working Pressure	10 Bar
Min. Regulation Calibration (Anti-Frost Position)	7°C
Maximum Regulation Calibration (Position)	30°C
Saving Condition (Position)	20°C
Max. Exercise Pressure	1000 KPa
Max. Differential Pressure	100 KPa
Min. Nominal Flow Rate "qm N" (DP=0.1 Bar) angle-straight	200-220 ltrs/h
Max. Storage Temperature	50°C
Hysteresis	0.4 K
Authority	0.9
Feedback	25 min
Differential Pressure Influence	0.3 K
Thermostatic Valve Supplied with Manual Regulating Wheel (Turning)	60° ≈ 1 K

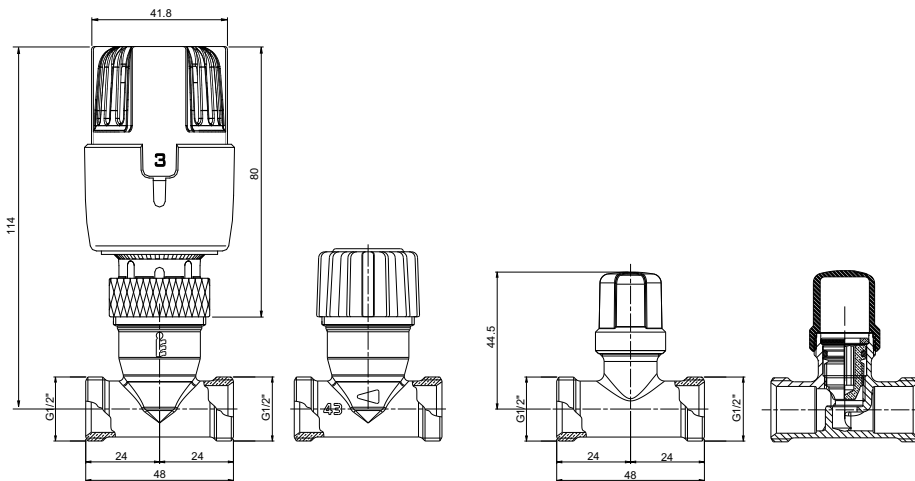

#### Features

Liquid filled sensor
Control range 0 - 30°C
Anti dirt trap minimalistic design
Frost protection setting
Anti chatter cartridge
Fully bi-directional

#### Key Features + Benefits

<b>1</b> Year Guarantee	<b>Max 110°C</b> Max. Flow Temperature	<b>Max 10 Bar</b> Max. Operating Pressure
-------------------------------	--	---

#### Certifications + Accreditations