

### S12 Long Neck Single Lever Mono Kitchen Mixer 4E2020

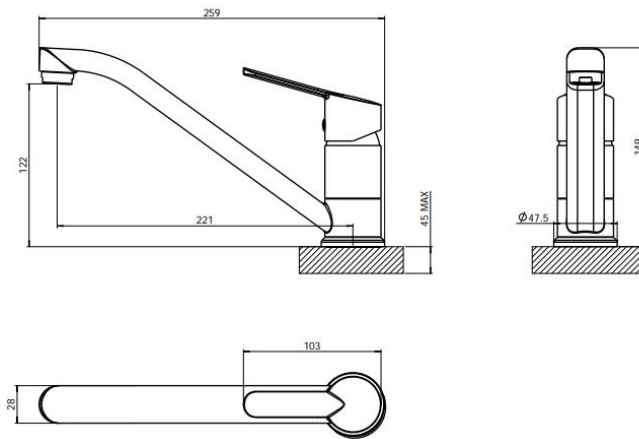

#### Specification

Finish	Chrome Plate
Dimensions	149(h) x 48(w) x 259(d) mm
Weight	0.9kg
Body	Brass
Fittings	Metal plate, washer, stud & locking nut
Connection	M10- DN8 Flexible hoses with 1/2" BSP threaded ends
Max Static Pressure	16
Min Dynamic Pressure	0.1
Max Dynamic Pressure	6
Max Water Temperature	60°C

#### Flow Rates

Pressure	0.1	0.5	1.0	3.0
Flow Aerator	-	-	-	-
Flow Straightener	2.0	7.5	11.2	20.4

All Pressures in Bar. All flow in L/Min. Dimensions supplied are nominal and subject to tolerance. Inclusion or restrictors (sold separately unless stated) will affect flow rate result. Performance details are based on trials under test conditions and for guidance only. The Company reserves the right to change product specification without prior notice.

#### Spares

Cartridge	856127
Flexible Hose (Pair)	28906

The Company is not responsible for the installation of the spares supplied, which must always be fitted by a competent person. Parts supplied are in many cases identical to the original component whilst others are offered as a suitable alternative. All spares listed are suitable for direct replacement unless stated. The Company reserves the right to change product specification without prior notice.

#### Key Features + Benefits

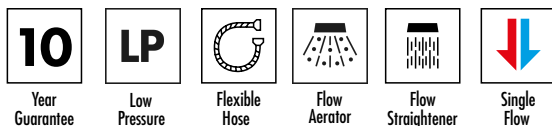

#### Certifications + Approvals



Tested at 0.2 Bar

1904376 - April 24