

Nostell 500mm Floor Standing Two Door Basin Unit INSTNOFS50PB

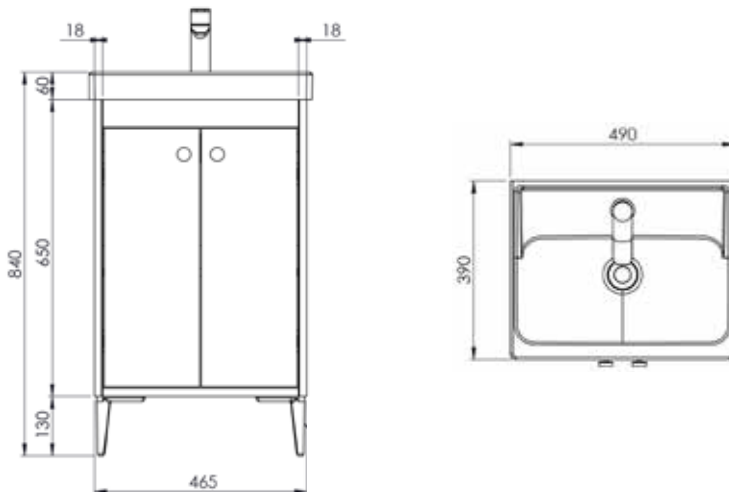

Specification

Finish	Matt Powder Blue
Dimensions	840(h) x 490(w) x 390(d) mm
Weight	13.3kg
Carcass Thickness	18mm
Carcass Material	MDF / MFC
Carcass Finish	Painted
Internal Cabinet Colour	Dark grey
Plumbing Void	50mm
Cabinet Fixing Type	Adjustable wall hangers
Door / Drawer Finish	Painted
Door / Frontal Material	MDF
Number of Doors	Two
Number of Drawers	None
Number of Internal Shelves	One (Adjustable)
Door Handing	-
Hinge / Runner Type	Soft close
Handle / Knob	Not supplied (sold separately)
Handle Centres	-
Leg Set	Not supplied (sold separately)
Pre-Drilled / Marked for handles	Pilot hole



Key Features + Benefits



5
Years
Guarantee



Soft Close
Doors



One Internal
Shelf



Plumbing
Void



One Taphole
Basin

Certifications + Approvals

Roper Rhodes

Brassmill Lane Trading Estate, Bath, BA1 3JF. Technical Support – Tel: 01225 303 900 Email: sales@roperrhodes.co.uk

All information on the data sheet is correct at the time of publication. All measurements are approximate and subject to standard tolerances.