

### Kensington Lever Mono Twin Lever Kitchen Mixer INST-KNL-KM

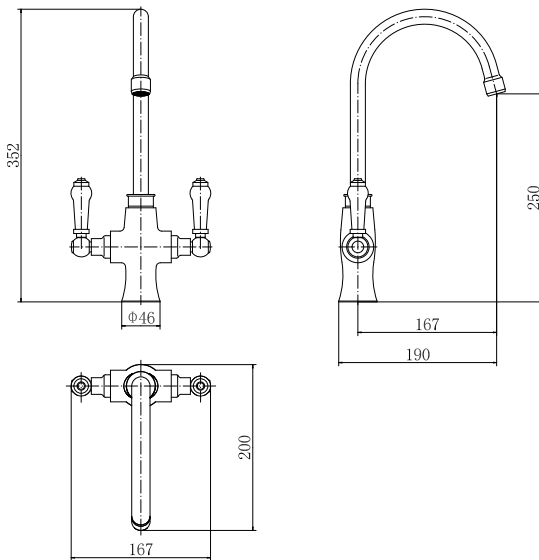

#### Specification

Finish	Chrome
Dimensions	345(h) x 180(w) x 200(d) mm
Weight	1.12kg
Body	Brass
Spout Material	Brass
Fittings	Metal plate, washer, stud & locking nut
Connection	M10 - DN6 Flexible hoses - 1/2" BSP thread ends
Cartridge Size	1/2" QT headwork
Flow Restrictor	No
Max Static Pressure	8.0 Bar
Min Operating Pressure	0.2 Bar
Max Operating Pressure	5.0 Bar
Max Water Temperature	80°C

#### Flow Rates

Pressure	0.2	0.5	1	3
Flow Aerator	4.9	7.3	10	17.1

All Pressures in Bar. All flow in L/Min. Dimensions supplied are nominal and subject to tolerance. Inclusion or restrictors (sold separately unless stated) will affect flow rate result. Performance details are based on trials under test conditions and for guidance only. The Company reserves the right to change product specification without prior notice.

#### Spares

Hot Cartridge	SP07-KNL-KM
Cold Cartridge	SP02-KNL-KM
Handle	SP39-KNL-KM
Handle Shroud	SP03-KNL-KM

The Company is not responsible for the installation of the spares supplied, which must always be fitted by a competent person. Parts supplied are in many cases identical to the original component whilst others are offered as a suitable alternative. All spares listed are suitable for direct replacement unless stated. The Company reserves the right to change product specification without prior notice.

#### Key Features + Benefits

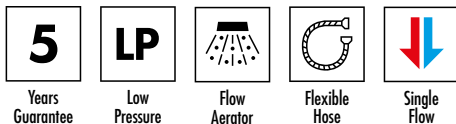

#### Certifications + Approvals

#### Aqualla Brassware

Unit 3 & 4 16 Crawfordsburn Road Newtownards County Down BT23 4EA. Technical Support – Tel: +44 (0) 28 9182 8000 Email: support@aquallabrassware.com

All information on the data sheet is correct at the time of publication. All measurements are approximate and subject to standard tolerances.