

### Kensington Twin Handle Mono Kitchen Mixer 4E1101



#### Specification

|                        |  |
|------------------------|--|
| Finish                 | Chrome   |
| Dimensions             | 342(h) x 55(w) x 228(d) mm                         |
| Weight                 | 1.68kg   |
| Body                   | Brass  |
| Spout Material         | Brass  |
| Fittings               | Metal Plate, Washer, Stud + Locking Nut            |
| Connection             | M12 - DN8 Flexible Hoses with 1/2" BSP Thread Ends |
| Cartridge Size         | 1/2" NR Headwork                                   |
| Flow Restrictor        | No   |
| Max Static Pressure    | 16 Bar   |
| Min Operating Pressure | 0.1 Bar  |
| Max Operating Pressure | 6 Bar  |
| Max Water Temperature  | 60°C   |

#### Flow Rates

| Pressure          | 0.2  | 0.5  | 1    | 3    |
|-------------------|------|------|------|------|
| Flow Straightener | 10.2 | 19.7 | 29.3 | 53.1 |

All Pressures in Bar. All flow in L/Min. Dimensions supplied are nominal and subject to tolerance. Inclusion or restrictors (sold separately unless stated) will affect flow rate result. Performance details are based on trials under test conditions and for guidance only. The Company reserves the right to change product specification without prior notice.

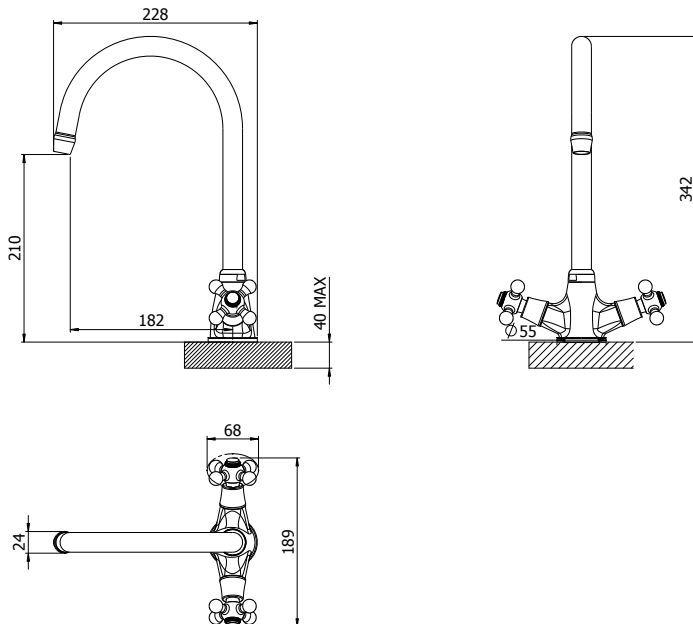

#### Key Features + Benefits

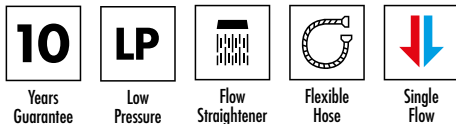

#### Certifications + Approvals

Flow Rate – 10.2 l/min

Tested at 0.2 Bar