

los Chef Infrared Single Lever Kitchen Mixer INST-IOS-KM



Specification

Finish	Chrome
Dimensions	501 (h) x 103(w) x 290(d) mm
Weight	1.90kg
Body	Zinc
Spout Material	Stainless Steel
Fittings	Plastic lock nut, plastic mounting seat, metal washer, rubber washer
Connection	M8, 1/2, DN6
Cartridge Size	#28 Cartridge
Flow Restrictor	No
Max Static Pressure	8.0 Bar
Min Operating Pressure	1.5 Bar
Max Operating Pressure	5.0 Bar
Max Water Temperature	60°C

Flow Rates

Pressure	0.2	0.5	1	3
Flow Aerator	n/a	n/a	3.28	6.1

All Pressures in Bar. All flow in L/Min. Dimensions supplied are nominal and subject to tolerance. Inclusion or restrictors (sold separately unless stated) will affect flow rate result. Performance details are based on trials under test conditions and for guidance only. The Company reserves the right to change product specification without prior notice.

Spares

Cartridge SP24-IOS-KM

Solenoid Valve Assembly SP11-IOS-KM

The Company is not responsible for the installation of the spares supplied, which must always be fitted by a competent person. Parts supplied are in many cases identical to the original component whilst others are offered as a suitable alternative. All spares listed are suitable for direct replacement unless stated. The Company reserves the right to change product specification without prior notice.

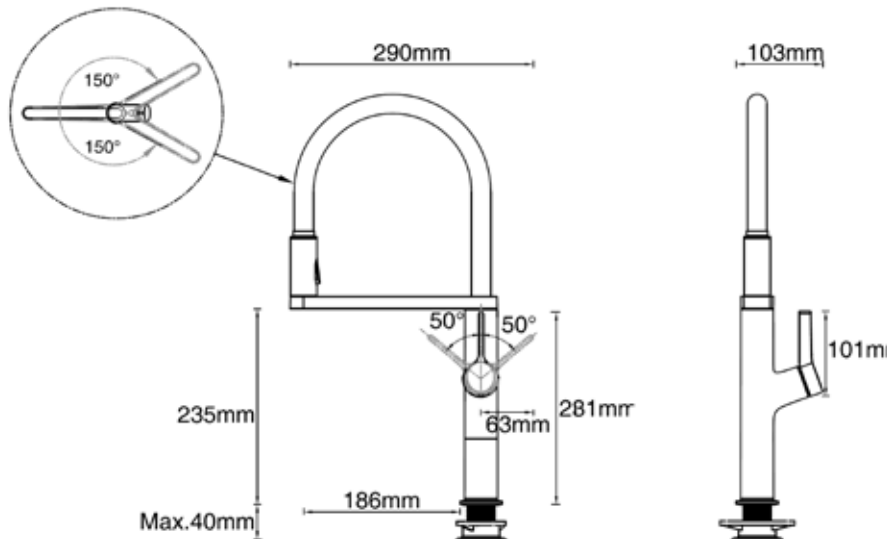

Key Features + Benefits

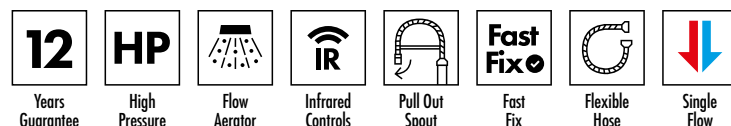

Certifications + Approvals

Aqualla Brassware

Unit 3 & 4 16 Crawfordsburn Road Newtownards County Down BT23 4EA. Technical Support – Tel: +44 (0) 28 9182 8000 Email: support@aquallabrassware.com

All information on the data sheet is correct at the time of publication. All measurements are approximate and subject to standard tolerances.