

Installation Instructions

Inspection

Please read carefully. Check your tray for any visible signs of damage.

Standard & Riser

LOW PROFILE & 80MM HEIGHT

Please note that this inspection should be done prior to installation.

The fitting of this tray will be seen as acceptance of quality.

Instructions must be adhered to as the manufacturers will not accept responsibility for incorrect installation.

IMPORTANT: We recommend top access 50mm easy clean wastes. Wastes should be fitted with rubber seals or silicone (not putty, etc). DO NOT OVER TIGHTEN.

If this shower tray is installed in conjunction with a steamer, the steam outlet must be at least 300mm from the top of the shower tray.

STANDARD INSTALLATION INSTRUCTIONS

- Before installation prepare a rigid base of concrete or marine ply with suitable recess or cut out for the waste.
- Cover the base with a layer of weak cement mix (sand/cement ratio 5:1).
- Place shower tray with waste fitted on the prepared cement bed, check for level and allow to set.
- Finally connect waste fitting and check for leakage. See examples **A** and **B** for fitting and **C** for finish.

Ensure tray is level and drains correctly. The shower tray has been designed with a built-in fall to allow correct water drainage.

NO RESPONSIBILITY WILL BE ACCEPTED UNLESS THE INSTRUCTIONS ARE FOLLOWED.

a) Straight onto floor

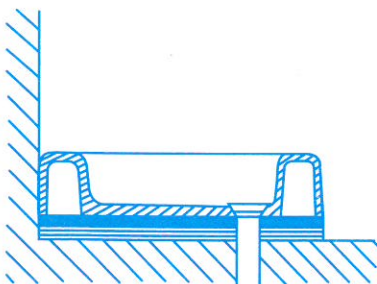

IMPORTANT

This product must be bedded on a weak 5:1 sand/cement mix on a solid base of either concrete or marine ply in all installations. This smooths out any undulations between the floor and the tray base.

b) Raised application

Make sure the distance between the struts is sufficient to accommodate the waste trap depth.

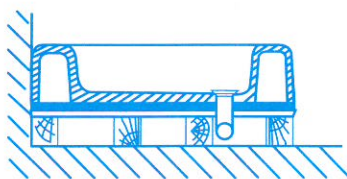

IMPORTANT

This product must be bedded on a weak 5:1 sand/cement mix on a solid base of either concrete or marine ply in all installations. This smooths out any undulations between the floor and the tray base.

c) Finish

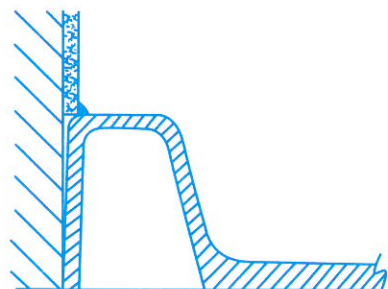

To prevent the possibility of water damage check all connections are water tight and that the tray is adequately sealed along the tiling line

RISER INSTALLATION INSTRUCTIONS

Carefully unwrap your shower tray.

Lay the tray face down on a dust sheet.

Fix the legs into the inserts incorporating the panel clips as shown in 1 & 2 diagrams

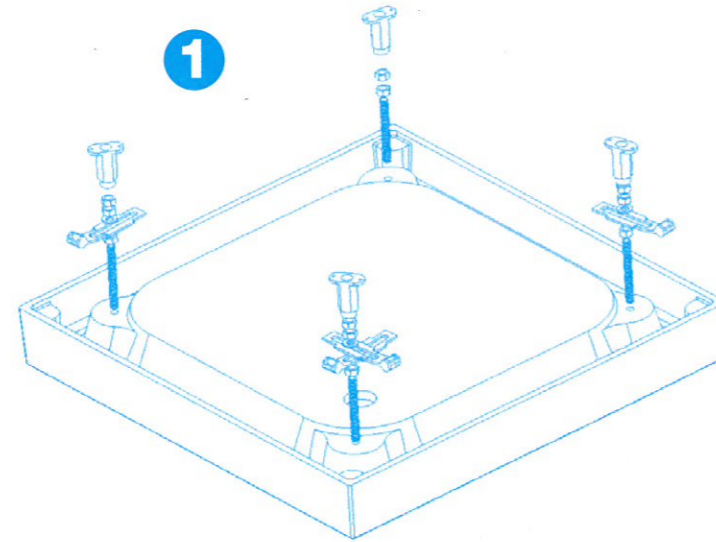

1

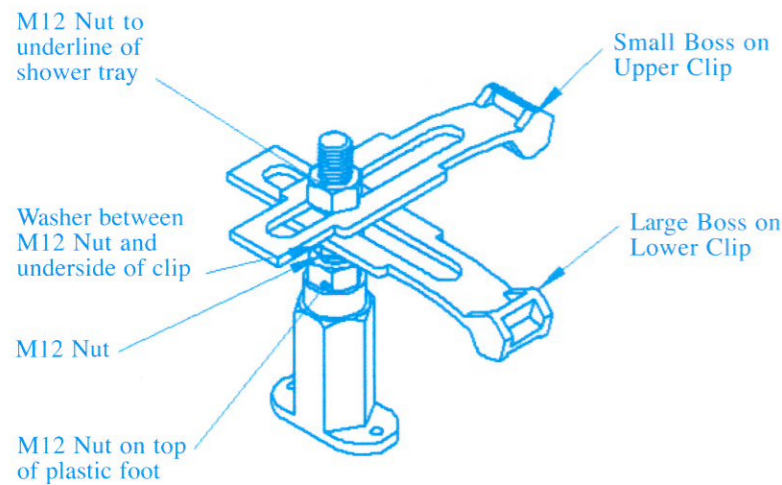

2

Position the tray in situation and level to the correct height as shown in diagram 4.

When using upstand trays mark the wall and chase into the plaster as in diagram 3.

3

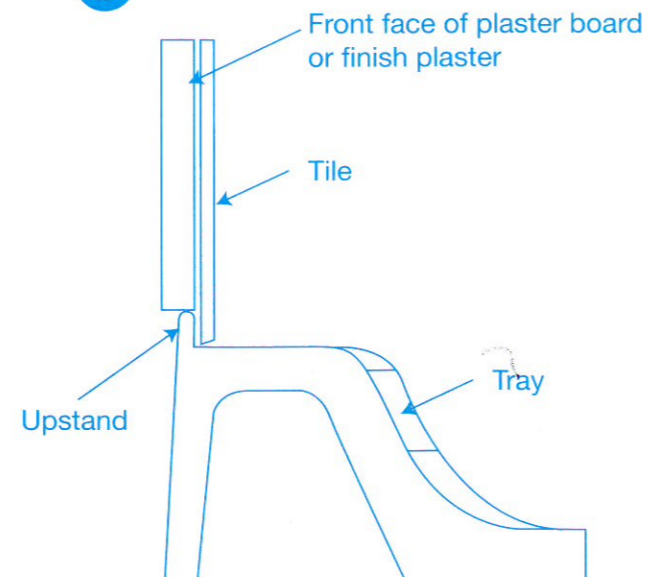

Make all plumbing connections, screw down accessible legs and remove the protective film from the tray

At this point a dust sheet or other protection in the tray base is required.

Commence tiling.

N.B. For flat top trays it is recommended that an adhesive, flexible tiling upstand be used.

- After the tiling and grouting is completely dry (approx 24 hrs), silicone sealant can be applied to the joint between the tray and the tiles as shown in diagram 4.
- The panel can then be fitted into the retaining clips. A small batten (not supplied) should be fitted to locate the base of the panel, to prevent the panel bottom pushing in see diagram 4.

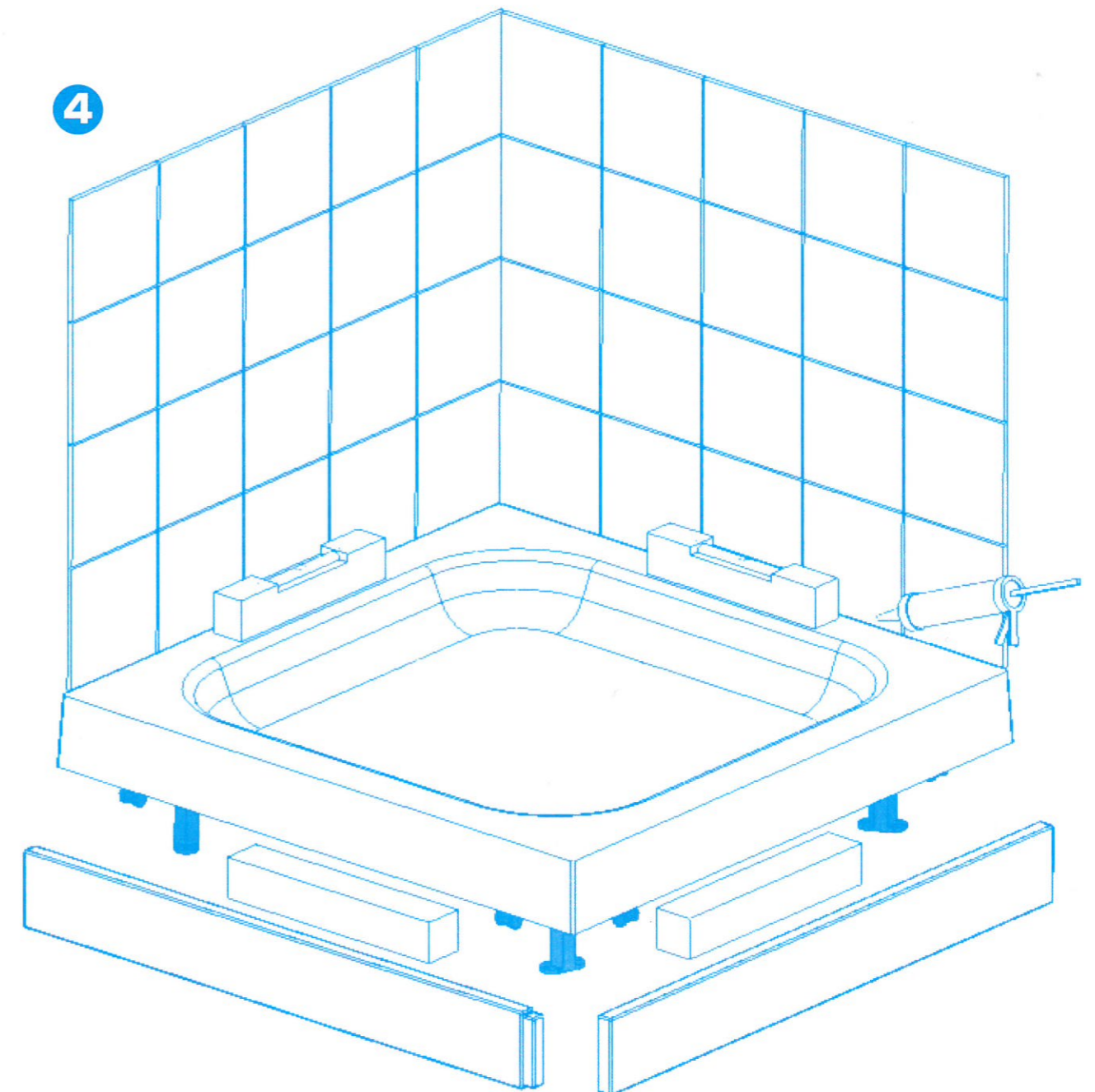

4

MAINTENANCE

As good as new finish can be maintained by following these guidelines:

- 1) Dry out the tray fully after every use, to avoid build-up of limescale and soap residue.
- 2) Clean the shower tray regularly using a damp cloth or sponge, followed by a soft dry cloth.
- 3) Occasionally use a non-abrasive cleaner to remove stubborn stains.

1. WARRANTY: LIMIT OF RESPONSIBILITY

- 1.1 The Company warrants that it will (at the Company's choice) either repair or replace, or refund the full purchase price of any goods which are accepted by the Company as being defective or not in accordance with the contract or any express description or representation given or made by or on behalf of the Company in respect of the goods within a period of 12 months from despatch of such goods from the Company's works ("the warranty period") save that this warranty shall not apply where the defect or fault is attributable to defective materials supplied by third parties where the Customer's only remedy will be against that third party or where the defect or fault is attributable to the goods not being installed or maintained in accordance with the Company's installation and maintenance instructions. The Customer's remedies in respect of any claim under the foregoing express warranty or any condition or warranty implied by law or any other claim in respect of the goods or any workmanship in relation thereto (whether or not involving negligence on the part of the Company) shall in all cases be limited to repair, replacement, reperformance or refund of the purchase price as aforesaid and any condition or warranty implied by law shall cease to apply after the expiry of the warranty period; and the Company shall not in any circumstances be liable for any damages, compensation, costs, expenses, losses or other liabilities, whether direct or consequential, and any other remedy which would otherwise be available in law in hereby excluded except to comply with the specification or in respect of any delivery or installment of any order or any part there of shall not entitle the Customer to cancel or refuse delivery of or payment for any other order, delivery or installment or any part of the same order, delivery or installment.
- 1.2 Where the Company is called out in respect of allegedly defective goods but declines to accept the goods are defective, the Company reserves the right to make a charge in respect of that visit.