

INSTINCT®

Opel - Gloss White Toilet Seat (INST03010)

Thank you for purchasing this toilet seat. Please read the instructions carefully before use to ensure a safe and satisfactory operation.

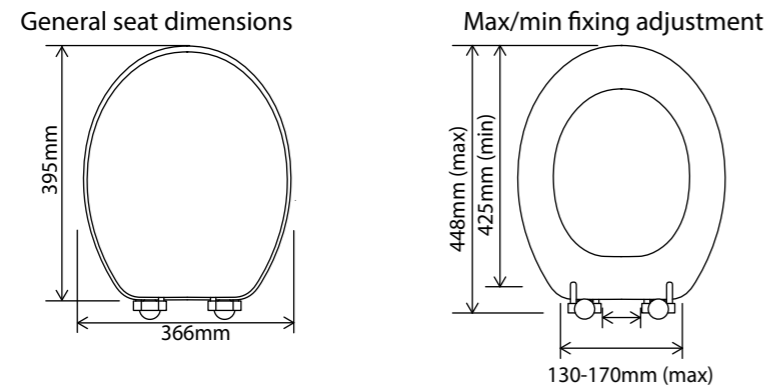

Pre-assembly preparation

Please ensure instructions are read in full before attempting to assemble this product.

Please check the pack contents before attempting to assemble this product. A full checklist of components is given in this leaflet. If any components are missing, please contact us.

The fittings pack contains SMALL ITEMS which should be KEPT AWAY FROM YOUNG CHILDREN.

Fittings and parts checklist

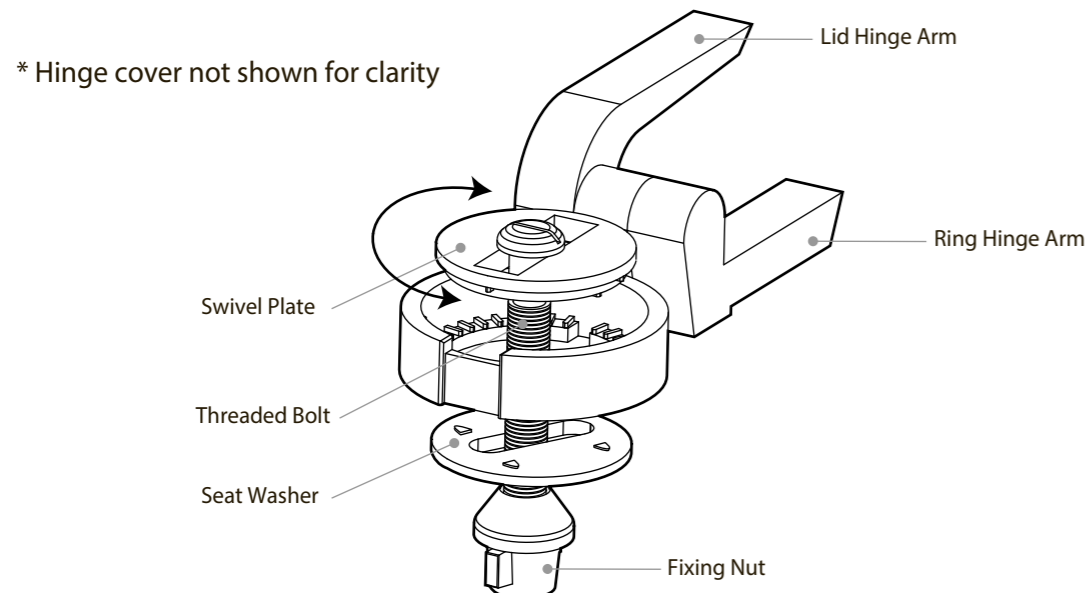

Step by step assembly instruction

The fixing bolt is inserted into the hinge body assembly and then bolted to the toilet pan with the Locking nut.

It is essential that the assembly is fitted as per the diagram, note that the main locking nut is the correct way up. The locking nuts must be tightened properly, this will require the use of a spanner or pliers. Failure to adequately tighten the locking nuts may result in the seat moving around on the pan. Care must be taken however not to over tighten as this could result in damage to the toilet pan.

After a few days use, check the nuts are still tight - this is necessary as the rubber seat washer will slowly compress in the first few days of use. If the seat lid or ring will not stay in the raised position then move it further forward on the pan.

Adjustment

By rotating the disk within the hinge body assembly it is possible to adjust the position of the fixing bolts. In addition to this rotating action, by sliding the fixing bolt left and right within the slot in the disk it is possible to adjust the fixing bolt position further. This sliding/rotating action allows for a wide range of fixing positions. This is necessary in order to match the distance between the two holes in the toilet pan and to adjust the forward/backward position of the seat.

Care and maintenance

After a few days check that the fixings are still tight. This is necessary as the rubber components will compress during the first few days. Clean surfaces with a soft damp cloth and mild soap solution and dry afterwards. Do not scrub or scour. Do not use abrasive cleaning agents. Do not stand on the lid or ring of your toilet seat. When using abrasive, corrosive or chlorine-based cleaners for the toilet bowl, ensure that these do not come into contact with the seat. Also keep the seat and cover in an upright position until all cleaner has been flushed away. Failure to do so can lead to discolouration of surfaces or rusting of metal parts which will not be covered by the guarantee.

Safety instructions

Periodically check all fixings to ensure none have come loose and re-tighten where necessary. Please take care when handling or moving the toilet seat as careless handling may cause damage or injury. The toilet seat can be dangerous if incorrectly installed. Assembly should be carried out by a competent person. No liability will be accepted for damage or injury caused by incorrect product installation or assembly.

Customer Services:

Brassmill Lane Trading Estate, Bath, BA1 3JF | T. 01225 303900 | F. 01225 448877