

# INSTINCT®

---

## Cool

# Safe Touch Shower Mixing Valve

## IN20015CP

### Installation and Maintenance Instructions

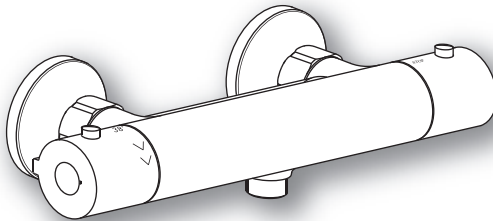

In this procedure document we have endeavoured to make the information as accurate as possible. We cannot accept any responsibility should it be found that in any respect the information is inaccurate or incomplete or becomes so as a result of further developments or otherwise.

© Intatec Ltd. 2013

# INSTINCT®

---

## Introduction

This installation guide has been produced for the Cool safe touch shower mixing valve. These instructions cover the installation, operation and maintenance. Please read the enclosed instructions before commencing the installation of this product, please note;

**We recommend that the installation of any INSTINCT product is carried out by an approved installer.**

The installation must be carried out strictly in accordance with the Water Supply (Water Fitting) Regulations 1999 and any local authority regulations.

If in doubt, we would recommend that you contact either your local water authority, the secretary of the Water Regulations Committee at WRc on Tel: 01495 248454 or Institute of Plumbing on Tel: 01708 472791.

All products **MUST** be re-commissioned to suit site conditions to ensure optimum performance levels of the product are obtained.

## Safety

This thermostatic shower must be installed and commissioned correctly to ensure that water is supplied at a safe temperature to suit the users.

43°C is the maximum mixed water temperature from a shower mixer. The maximum temperature takes account of the allowable tolerances inherent in thermostatic shower mixers and temperature losses.

**It is not a safe washing temperature for adults or children.**

The British Burns Association recommends 37 to 37.5°C as a comfortable washing temperature for children. In premises covered by the Care Standard Act 2000, the maximum mixed water outlet temperature is 43°C.

## Products

Cool Thermostatic Safe Touch Bar Shower with fast fix brackets and flexible riser kit.

IN20015CP

## Check Content

Before commencing remove all components from packaging and check each component with the contents list.

Ensure all parts are present, before discarding any packaging. If any parts are missing, do not attempt to install your INSTINCT shower valve until the missing parts have been obtained

The shower valve is supplied with the two connectors, containing the filters and check valves, and the union nuts assembled to the body.

# INSTINCT®

## Components

### Item Qty Component

1	1	Body
2	2	Union nut
3	2	Connector with filter & check valve
4	2	Sealing washer

### Item Qty Component

5	2	Concealing plate
6	2	Compression face
7	2	Olive
8	2	Wall bracket

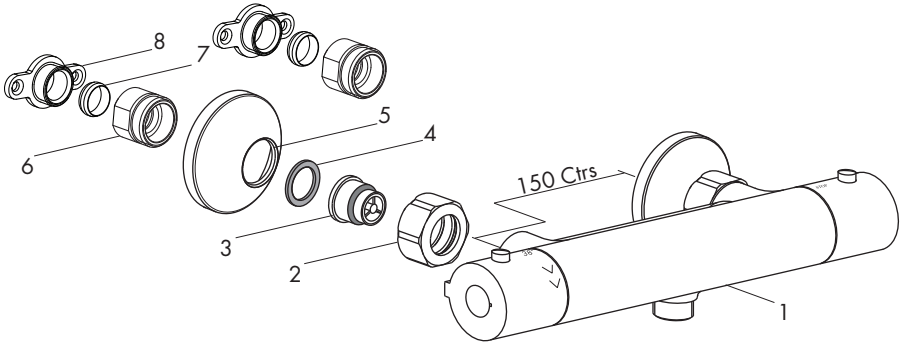

## Technical Data

This INSTINCT Cool thermostatic shower valve is suitable for installations on all types of plumbing systems, including gravity supplies, fully pumped, modulating combination boiler, unvented water heater and unbalanced supplies i.e. Cold Mains & Tank Fed Hot. They are not suitable for non-modulating combination boilers.

Max Inlet Pressure (Static)	12 bar	Max Inlet Temperature	85°C
Max Inlet Pressure (Dynamic)	5 bar	Pre Set Factory Temp Setting	43°C
Min Operating Pressure (Dynamic)	0.2 bar	Temperature Stability	±2°C
Max Unbalanced Pressure Ratio	5:1	Min Temp Differential to	
Inlet Connections (Body only)	G $\frac{3}{4}$ "	ensure fail-safe between hot	
Outlet Connection	G $\frac{1}{2}$ "	and cold supplies	10°C

## Unvented Mains Pressure System

The drawing shows a typical installation of a shower mixing valve in conjunction with an unvented hot water system. This type of installation must be carried out in accordance with Part G of the Building Regulations.

Whilst pressures are theoretically equal (balanced) most unvented hot systems have a pressure reducing valve on the incoming cold water prior to the hot water storage vessel. This means that the hot and cold pressures can be significantly different.

## Unvented Mains Pressure System

Most unvented systems use an inlet manifold located directly after the pressure reducing valve.

It is recommended that the cold supply be taken from one of the outlets of the manifold directly to the shower as an independent supply.

For systems without a manifold unit after the pressure reducing valve and where the cold water supply pressure is significantly higher than the hot supply we recommend that a separate pressure reducing valve is fitted to the cold supply, as close as possible to the shower valve and with no draw off points between it and the shower valve.

Flow regulators are required for installations where a PRV is not fitted to ensure simultaneous demand is accounted for.

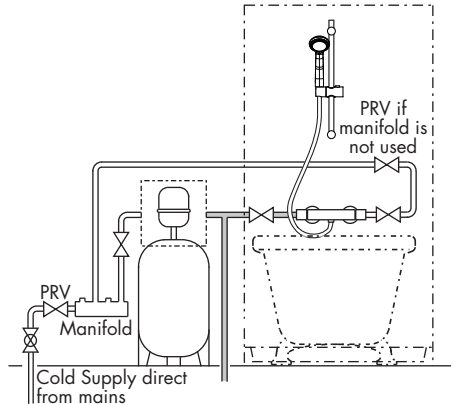

## Pumped Systems

Pumped systems use a booster pump to increase the pressure of the gravity fed water supplies.

These booster pumps are used where the head of water is insufficient to provide a satisfactory shower or where a high performance shower is required.

Please ensure that the performance of the pump is matched to suit the shower.

Follow the instructions for gravity fed installations taking into account the installation requirements of the pump.

Ensure that the hot and cold water storage capacity is sufficient to supply the shower and any other draw off points that may be used simultaneously.

Most pumps require a minimum head of water to allow the flow switches to operate automatically. Where this is not available a negative head kit may be required to operate the pump.

Please consult the pump manufacturer's installation requirements

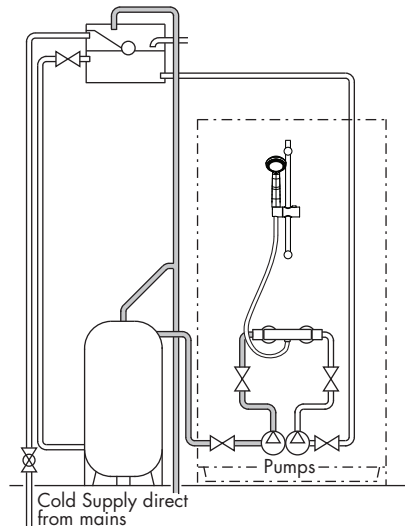

## Modulating Combi Boiler / Instantaneous Gas Water Heater

The drawing shows a typical installation of a shower valve in conjunction with a combination boiler.

Combi boilers will produce a constant flow of water at a temperature within its operating range. However we recommend that the system should supply hot water in excess of 60°C.

The hot water flow rates are dependant upon the type of boiler / heater used and the temperature rise required to heat the cold water to the required temperature.

The cold water flow rates may be much greater as they are generally unrestricted from the mains cold water supply. To ensure relatively balanced flow rates, we recommend that a pressure reducing valve or 6 l/min flow regulator is fitted in the cold water supply pipe.

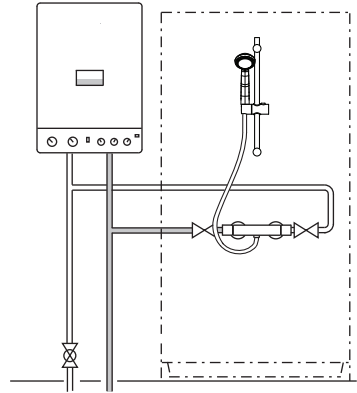

## Gravity System

The drawing shows a typical installation of a shower valve on a gravity supplied system.

Please note the minimum head pressure required to ensure operation of the valve. In accordance with good plumbing practice, we recommend that a totally independent hot and cold water supply be taken to the valve.

The cold water supply must be connected directly to the water cistern. The hot water supply should be connected to the hot water cylinder via an Essex flange or Sussex flange or to the vent or a draw off pipe as close as possible to the top of the cylinder.

For equal tank fed pressures there is no need to fit the flow regulators. This installation is the recommended minimum for gravity supplies. For systems with less than 2 metre head pressure, we recommend that a suitable booster pump is fitted to increase the supply pressure.

## Cold Mains & Gravity Hot Supplies

If the cold supply to the shower is direct from the cold water mains and the hot water supply is gravity fed from the cold water cistern via the hot water cistern you **MUST** fit a pressure reducing valve or a 6 l/min flow regulator.

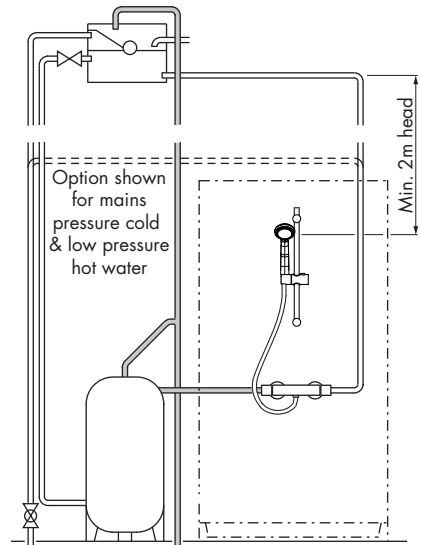

## Site Preparation

**It is important to plan the installation thoroughly to suit site conditions before commencing.**

- Before commencing the installation ensure site conditions are suitable.
- The shower mixing valve is designed for concealed pipework, whether in a solid or studded wall.
- The thickness of wall tiles, plaster or plaster board should all be considered when routing the hot and cold supply pipes.
- The supply pipes can come from below, above, or the side before protruding through the wall brackets and if not embedded into the wall with plaster should be fixed securely to the studding.
- The valve requires the wall brackets to have 150mm centres and sufficient copper pipe must protrude through the wall bracket to make a water tight joint using the olive and compression face.
- Ensure the shower valve will be horizontal when installed.
- The wall brackets must be secured firmly to the wall or to the studding in a cavity wall.
- The whole system should be thoroughly flushed, prior to the connection of the hot and cold water supplies to the shower mixing valve, to remove any debris that may be in the supply pipework.
- Ensure there are no joint leaks before finishing the wall.
- Isolation valves must be fitted in an accessible position to both the hot and cold supplies should the valve need to be isolated in the future for servicing.

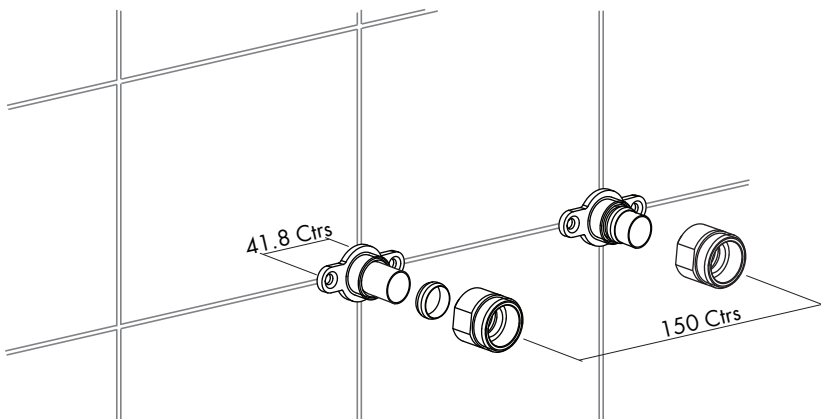

## Fitting the Brackets

- Apply silicone sealer to the back of both wall brackets, fit to the 2 protruding copper pipes, press to the wall and secure both brackets with 2 counter sunk screws.
- Add the olives and then the compression faces and tighten until water tight joints are made.
- Apply a bead of silicone sealer around the inside edge of the concealing plates, position over the compression faces and press firmly to the wall.

## Installing the Shower Valve

- Fit the shower valve to the wall bracket assemblies using the sealing washers (4) and using a suitably sized spanner, tighten the union nuts taking care not to damage the finish on the shower valve, do not over tighten.
- Turn on the water supplies and check that all joints are water tight.

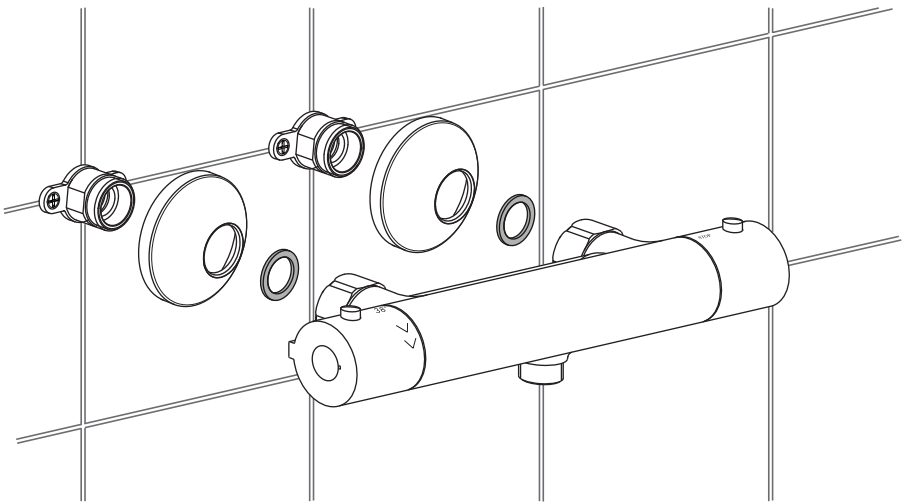

# INSTINCT®

## Calibration

This INSTINCT Cool shower valve has a factory set outlet temperature of 38°C via the security setting. This is based on a balanced supply pressure and a stable hot water inlet temperature of 65°C.

However, the calibration point **MUST** be checked and re-set as necessary to suit site conditions.

Care must be taken when re-calibrating the valve as **INCORRECT CALIBRATION CAN CAUSE INJURY**.

- Remove the cover (2), retaining screw (3) spring washer (4) and temperature control knob (5) by pulling away from the shower valve and the temperature stop ring (6).
- Fully open the flow control (1) and allow the outlet temperature to stabilise.
- Temporarily refit the control knob (5) and using a digital thermometer it is possible to increase or reduce the mixed water outlet temperature until 38°C is re-established, by slowly rotating the control knob.
- Remove the control knob (5) and refit the temperature stop ring (6) onto the splined section of the cartridge. The temperature control knob stop on the temperature stop ring (6) must align with the red dot (8) on the plastic splined section of the cartridge.
- Refit the temperature control knob in the reverse order ensuring that 38°C on the control knob is in the vertical position and positioned against the stop on the temperature stop ring.
- When the shower valve is in use the water temperature can only be increase by pressing the button on the control knob and rotation the knob in the direction of the red arrows.

**PLEASE NOTE THAT ONCE CALIBRATED, THE SECURITY SETTING WILL ONLY BE 38°C UNDER THE SUPPLY CONDITIONS USED FOR CALIBRATION.**

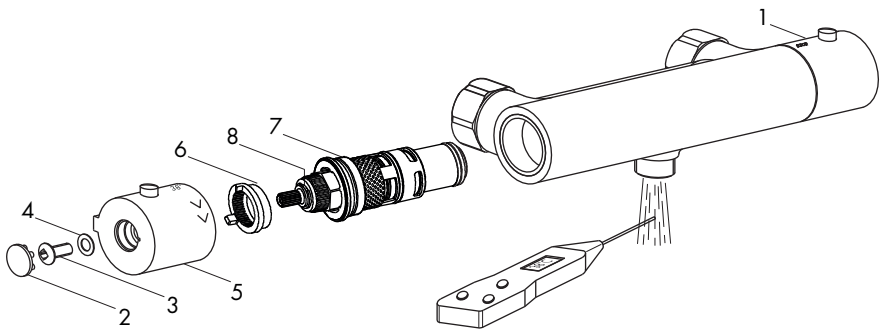



## Cartridge Replacement

- Isolate both the hot and cold water supplies
- Remove the cover (2), retaining screw (3), spring washer (4) and temperature control knob (5) by pulling away from the shower valve and the temperature stop ring (6).
- Using a suitable spanner unscrew the cartridge (7).
- Replace with a new cartridge.
- The shower valve must be re-calibrated after fitting the new cartridge following the procedure above.
- Refit the temperature stop ring (6) onto the splined section of the cartridge. The temperature control knob stop on the temperature stop ring (6) must align with the red dot (8) on the plastic splined section of the cartridge.
- Refit the temperature control knob in the reverse order ensuring that 38°C on the control knob is in the vertical position and positioned against the stop on the temperature stop ring.

## Aftercare

INSTINCT shower mixing valves have a high quality finish and should be treated with care.

An occasional wipe with a mild washing-up liquid on a soft damp cloth followed by a thorough rinsing is all that is required.

The nozzles in the hand set or overhead soaker should be cleaned periodically to remove any build up of debris or deposits which may affect the performance of the shower.

**Do not use** an **abrasive** or **chemical household cleaner** as this may **cause damage**.

## Spares

A full range of spares are available for this product.

**PLEASE NOTE:** Only genuine spares should be used.

## Problem Solving

The following details are supplied for on site queries, should you require any further assistance our Technical Department can be contacted directly on 01889 272199.

<b>Fault</b>	<b>Solution</b>
Showering temperature is not hot enough.	Ensure the hot water supply is at a constant temperature above 60°C. Check for air locks in the pipework.
The water goes cold during showering.	Insufficient stored hot water. When used with a combi boiler confirm that the boiler is still firing. Adjust the boiler to a minimum setting of 65°C which may not necessarily be the best flow rate.
When the water is set at cold, the showering temperature is too hot.	The hot and cold supply connections have been made in reverse.
The maximum showering temperature is too hot or when set to hot water runs to cold.	Check the commissioned maximum temperature of the shower valve. Check the connections to the valve have not been made in reverse.
The flow of water from the shower valve is low.	Check the filters are clean and the supply pressure is above 0.2 bar.
No flow of water	Ensure the valve has not fail-safed and check that there is hot and cold water flow to the valve. Ensure the check valves are not closed.

## Cleaning the Filters and Check Valve

If the flow of water from the shower valve is low the filters may be blocked with debris or in hard water areas with calcium deposits.

The two connectors containing the filter and check valve must be removed from the shower valve body.

This also applies if the check valves are failing to operate correctly.

- Isolate the hot and cold supplies to the shower valve.
- Disconnect the flexible hose and remove the shower valve by unscrewing the two union nuts.

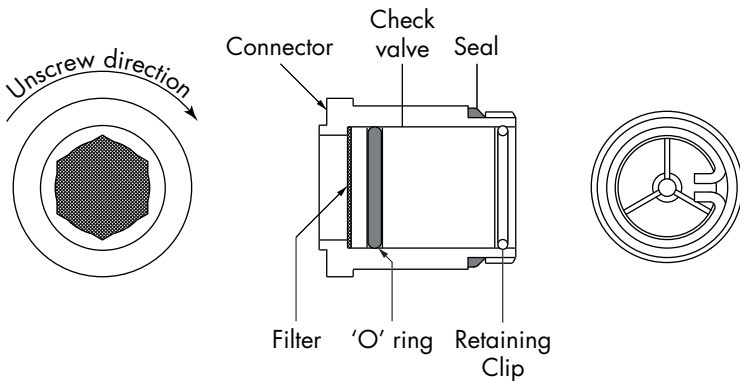

- Using a 12mm A/F hexagon wrench unscrew both connectors and the body.  
**NOTE:** these connectors have a left hand thread and therefore turn clockwise to unscrew.
- Remove the wire retaining clip, and push out the filters and check valves.
- Flush with clean water or with de-scaling solution - the manufacturer's instructions must be adhered to.
- Check the condition of the 'O' rings and seal on the connectors for damage.
- If any component is damaged or not functioning correctly it **MUST** be replaced before re-assembling.
- Apply washing up liquid or WRAS approved silicone grease to the rubber seals to ease assembly.
- Re-assemble in the reverse order, turn on the water supplies and check joints for leakage.
- The calibration of the shower must be checked and be re-calibrated if necessary.

# INSTINCT®

## Flexible Slide Rail - Components

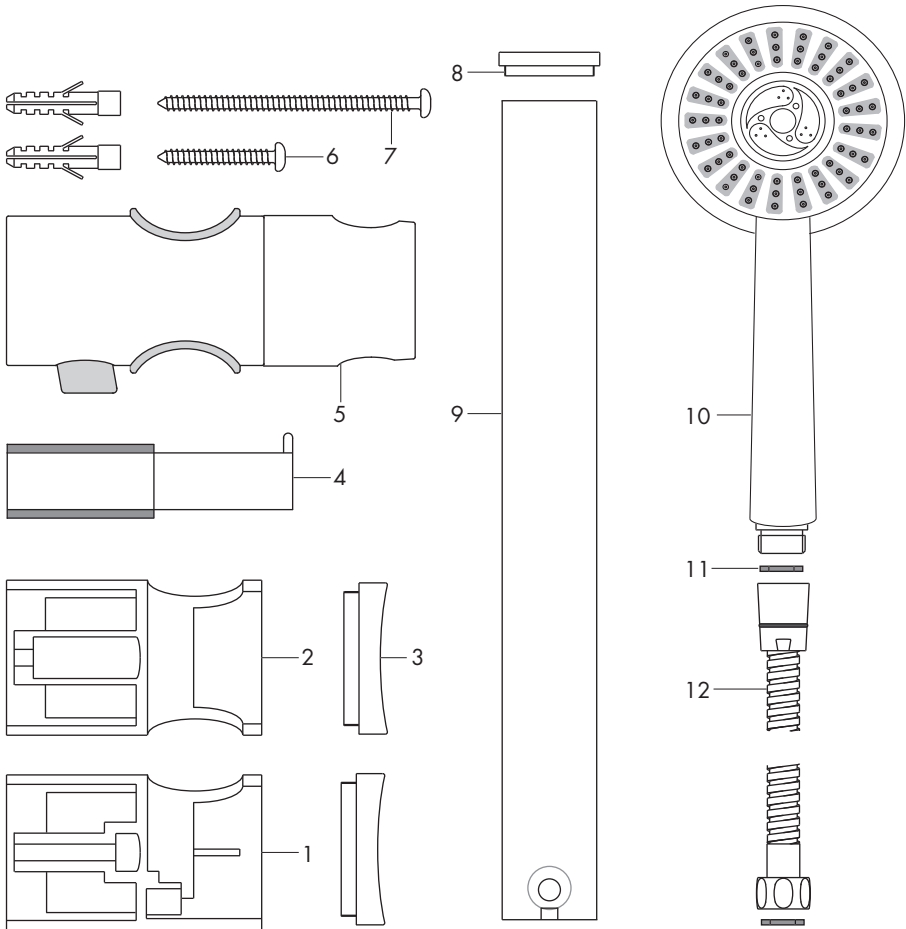

Item	Qty	Component	Item	Qty	Component
1	1	Bottom Wall Bracket	7	1	M4 x 30 Screw & Plug
2	1	Top Wall Bracket	8	1	Rail Cap
3	2	Cover	9	1	Rail
4	1	Flexible Tidy	10	1	Handset
5	1	Handset Holder	11	2	Sealing Washers
6	1	M4 x 70 Screw & Plug	12	1	Flexible Hose

## Slide Rail - Installation

The screws and wall plugs supplied are only suitable for use in solid walls. If the wall is plaster board or soft building block use special wall plugs obtainable from most DIY stores.

Ensure there are no supply pipes or cables where you intend to drill.

Where possible, drill holes between ceramic tiles (in the grout). If drilling into ceramic tiles use a ceramic bit.

This product must always be used and fitted in such a way as not to cause water damage, therefore should be located and directed towards a suitable shower tray.

Take care to use power tools safely.

Carefully remove the cover (3) from each wall bracket (1) and (2) to expose the fixing hole.

Drill the 6mm diameter hole for the bottom wall bracket (1).

To avoid cracking ensure the wall plug is pushed all the way behind the ceramic tile.

Using the 70mm long screw (7) provided temporarily secure the wall bracket (1) to the wall ensuring the correct orientation for the bracket.

Slide the top wall bracket (2) onto the riser rail (9) and position in the bottom wall bracket (1) ensuring that the slot at the bottom of the riser rail is located over the anti-rotational lug.

Locate the upper bracket onto the wall towards the upper end of rail, approximately 50mm from the end, ensuring the rail is vertical.

Mark round the upper wall brackets with a removeable marker onto the wall.

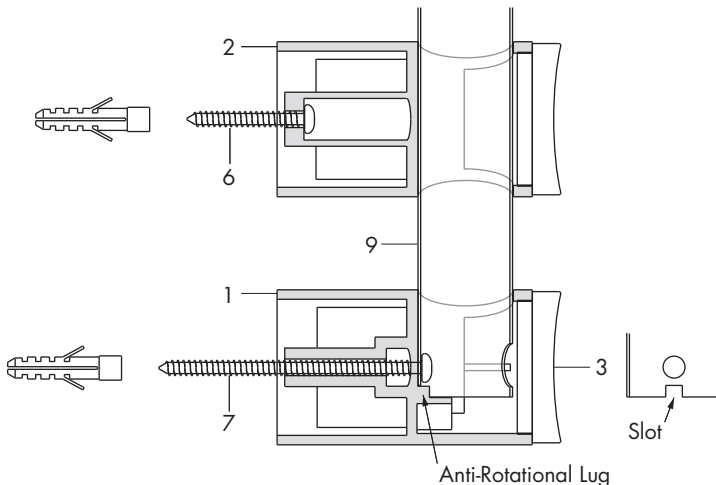

## Slide Rail - Dimensions

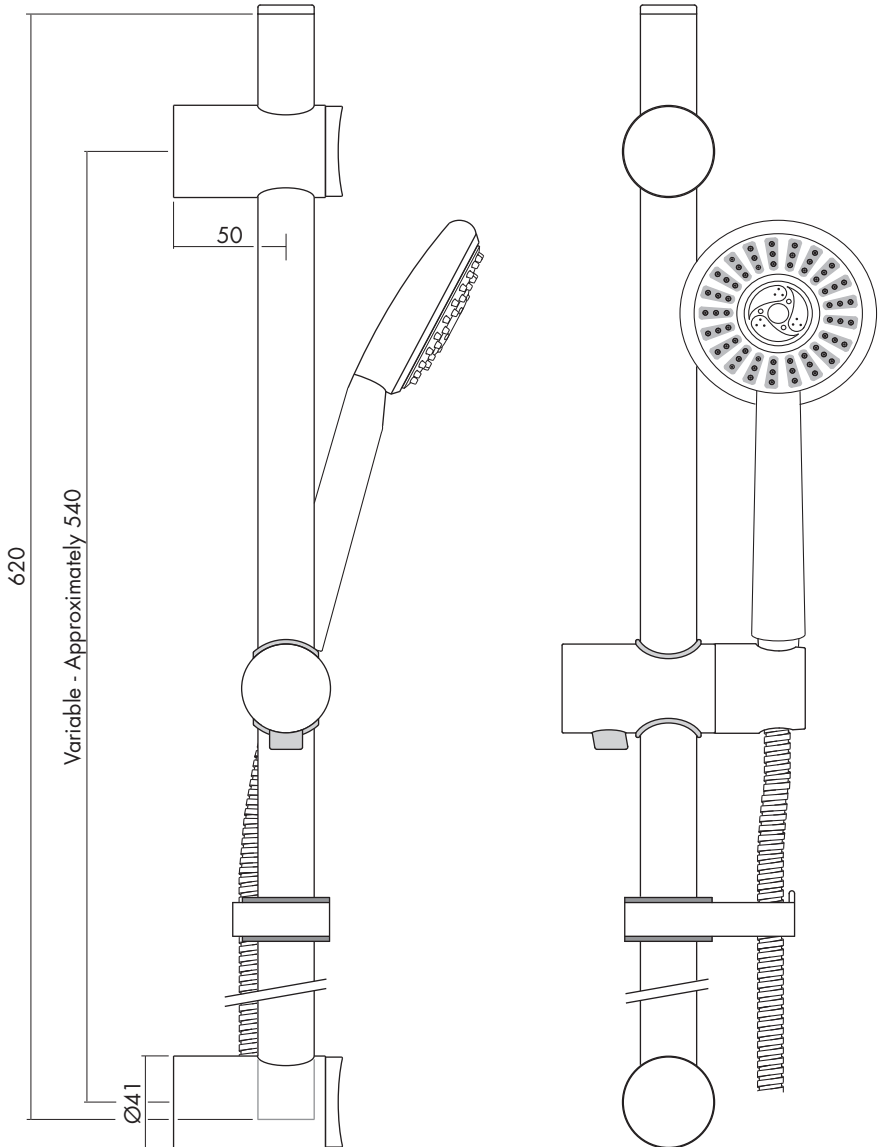

## Slide Rail - Installation

Position the top wall bracket (2) onto the wall within the markings and using the hole as a template, drill a 6mm diameter hole.

Fix the upper wall bracket to the wall using the 30mm long screw and secure.

Assemble the end cap (8) into the end of the rail without horizontal hole.

Assemble the handset holder (5) and the flexible tidy (4) onto the riser rail below the handset holder.

Unscrew the 70mm long screw (7) and remove from the bottom wall bracket (1).

Pass the rail assembly through the hole in the top wall bracket (2) and locate in the bottom wall bracket (1) ensuring that the slot at the bottom of the riser rail is located over the anti-rotational lug.

Pass the 70mm long screw through the hole in the rail and through the wall bracket and secure.

The head of the screw should be inside the rail as shown.

Refit the covers (3) into the wall brackets

Ensure the sealing washers (11) are inserted into both ends of the flexible hose (12) and connect the hose to the shower valve and the handset (10).

Turn on the shower valve and check joints for leakage.

**Intatec Ltd**  
Airfield Industrial Estate  
Hixon  
Staffordshire  
ST18 0PF

Tel: **01889 272 180**  
Fax: **01889 272 181**  
email: **sales@intatec.co.uk**  
web: **www.intatec.co.uk**

# INSTINCT<sup>®</sup>

---

E & O.E

© Intatec Ltd 2013

29-01-13