

# INSTINCT®

## Corner Entry

## Instruction Manual

### V2INC



PO Box 125, Whitworth Avenue,  
Aycliffe Business Park,  
Co Durham DL5 6WX

To obtain a copy of the Declaration of Performance for this product, please go to: [www.ce-dop.com](http://www.ce-dop.com), contact us on +44 (0) 1325 328034, or write to us at the above address, quoting the product reference number where possible.

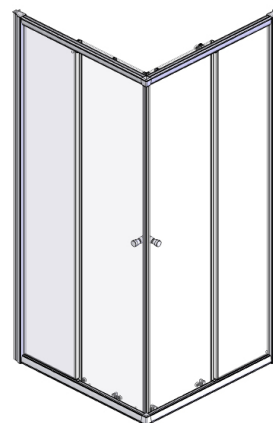

### IMPORTANT INFORMATION

Be aware toughened glass can shatter if not handled correctly. It should not be subjected to any sharp impact and it is essential to protect the glass by resting it on a soft protective surface during installation such as cardboard or carpeting. It is recommended to wear PPE at all times during installation.



#### PRE-INSTALLATION CHECKS

1. Check you have the correct product. Please look at the labels on the side of the product packaging.
2. Check all the product components are in the box and the fixing kits.
3. Unpack your product and handle it with care.
4. Please check the product for defects or damage, once the installation has commenced we cannot accept responsibility for any defects or damage.
5. Please take time to read these instructions prior to installing your product.
6. Before you commence any drilling check there are no hidden electrical cables and/or water pipes.
7. No attempt should be made to re-work the toughened safety glass.
8. The installation of the product should be performed by two persons.
9. It is strongly recommended that the walls the product is going to be installed on are vertical.
10. It is strongly recommended the product is fitted on a tiled surface or similar waterproof surface.
11. It is strongly recommended the walls are tiled and grouted before the product is installed.
12. If the walls and/or the tray are not level you will not achieve maximum adjustment of the product.
13. Pictures used are for illustration purposes only, product designs may alter slightly as a result of continuing product development.
14. We do not stipulate where the European Standard Kite Mark should be positioned on the glass when being factory assembled.
15. Please note that some natural misting may occur when you remove this product from its packaging, due to the addition of the glass protection pre-coating. If this does occur this can easily be removed with a soft, dry cloth.

#### Component Check List: Supplied

Description	Quantity
Wall Profiles	2
Panel Assemblies	2
Top and Bottom Rails	4
Door Magnets	2
Vertical Door and Panel Seals	2 of each
Panel to Horizontal Rail Seals	4
Handle Assemblies	2
Bearing Assemblies (Top)	4
Bearing Assemblies (Bottom)	4
Corner Mouldings	2
Door Glass	2

#### Equipment Check List: Not Supplied

Description
6mm Masonry Drill Bit
4.5mm Drill Bit
Mains / Battery Drill
Spirit Level
Screwdriver
Sealant Gun
Bathroom Sealant
Tape Measure
Pencil
Additional Fixings if going into Plasterboard etc.

#### Fixing Kit Components

Description	Quantity
Wall Plugs	6
40mm Screws	6
Frame Fixing Screws	8
9mm Screws	10
Screw Bases	16
Screw Cover Caps	16
Top Caps (Left Hand and Right Hand)	1 of each
2.5mm drill bit	1

#### CONSUMER GUARANTEE

Please make sure the purchaser/end user completes and returns the guarantee card which is enclosed with this product. Failure to validate the Guarantee will mean only the 1 Year Statutory Guarantee will apply.

## Step 1 - Pre-Installation Checks

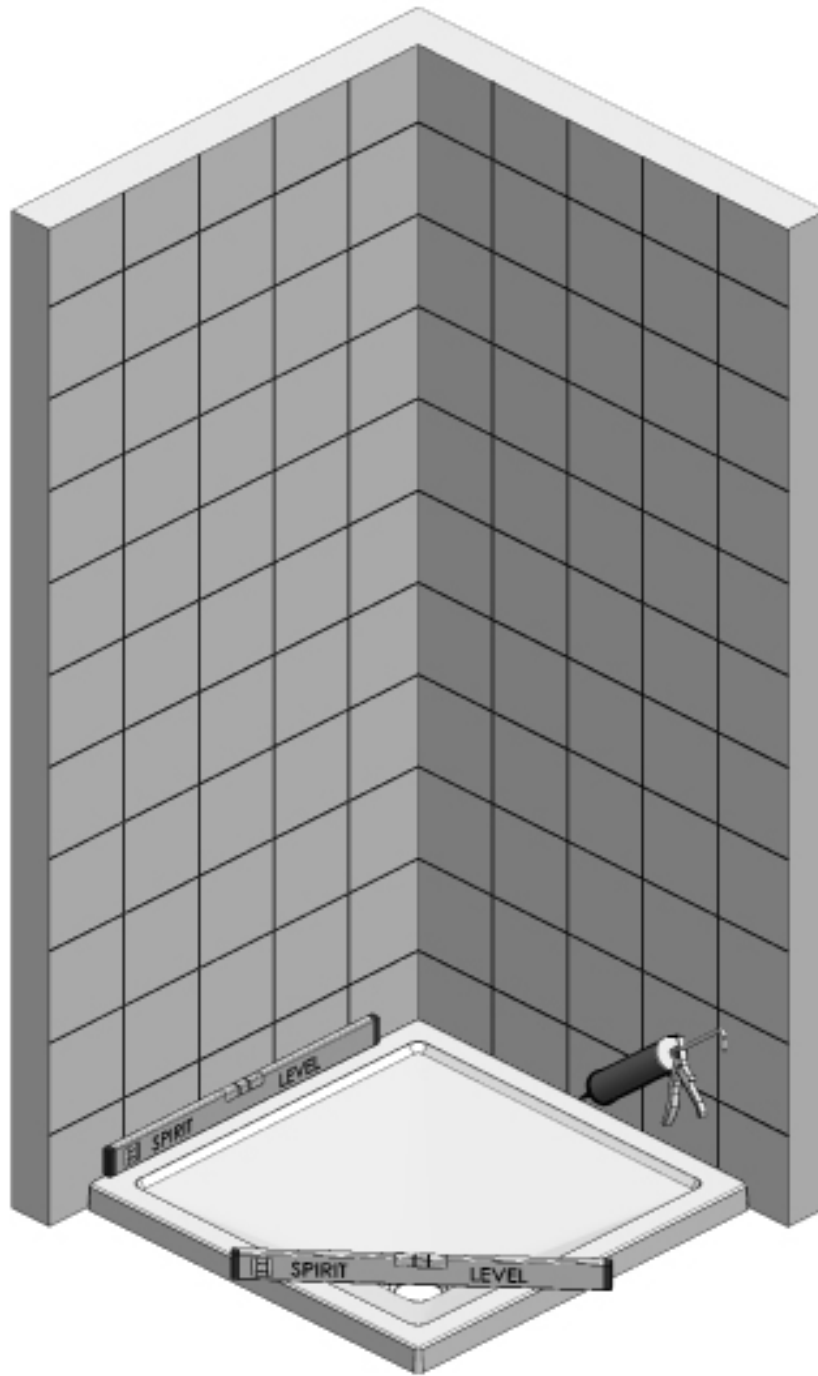

SPIRIT

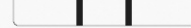

LEVEL

1. Check the tray is level on all sides (the bubble on the spirit level must be in the centre of the 2 lines).
  2. Stand in the tray and check that there is no adverse movement (correct if necessary).
  3. The walls should be tiled and grouted up to the tray.
  4. The tiles and the tray should be sealed using a good quality bathroom sealant.
- **Spray the seal and joints with the shower head and check for leaks when the silicon has cured.**
  - **Check the plumbing for leaks.**
  - **DO NOT plasterboard over the tray.**
  - **DO NOT grout the tiles when the enclosure has been fitted, the grout may discolour the aluminium profiles.**
  - **Make sure the tray is installed as per the manufacturer's instructions.**
  - **When all of the above has been completed please proceed to the Step 2.**

## Step 2 - Wall Profile Positioning

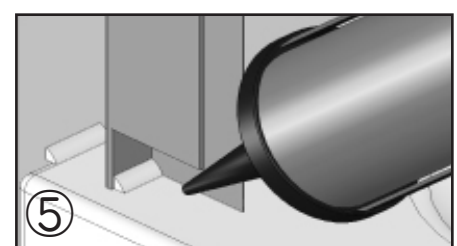
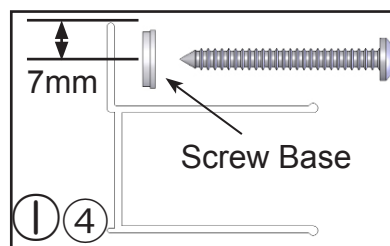
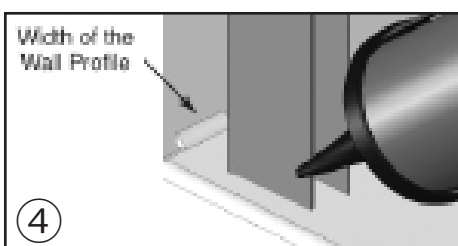
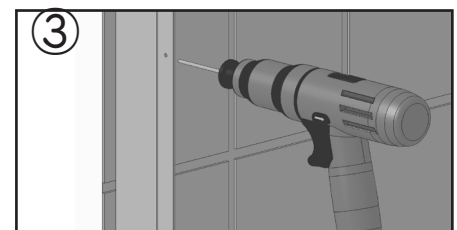
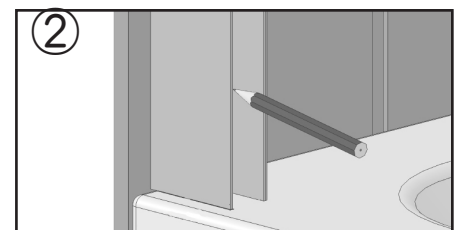
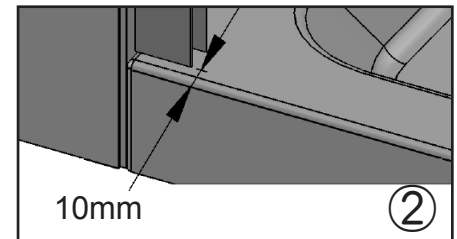
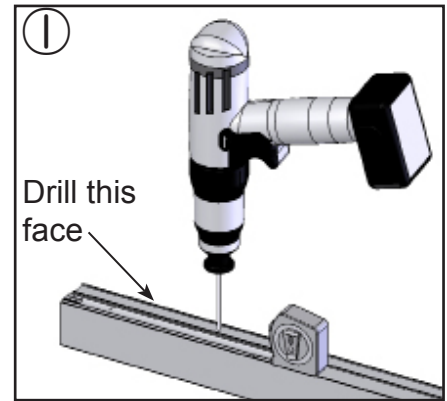
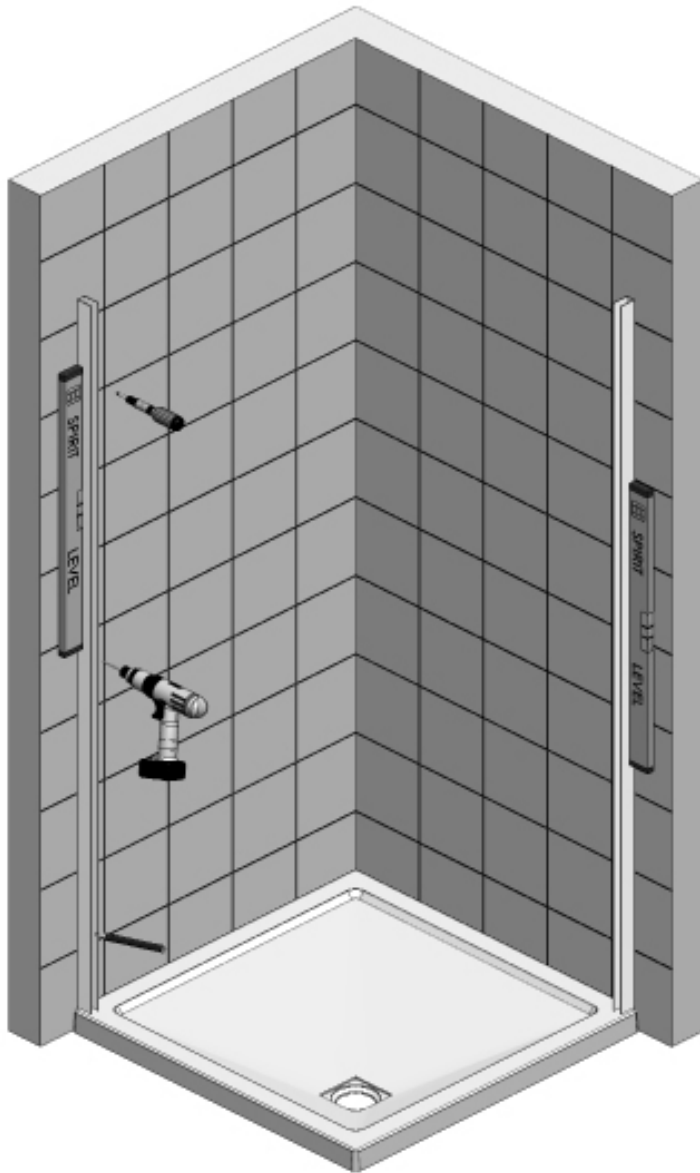

1. On both Wall Profiles drill three 4.5mm holes through the lip. Place them 7mm in from the edge and approximately 100mm from each end and the other positioned in the centre.
  - **Drill the holes from the back (through the face that goes to the wall) - deburr all holes.**
2. Place both Wall Profiles 10mm in from the outside of the tray. Make sure that both Wall Profiles are completely vertical using a spirit level and mark the wall through the holes with a pencil.
3. Drill the wall with a 6mm Masonry Drill Bit (not supplied) where the Wall Profiles are to be positioned. Fit the Wall Plugs supplied (if going in to a brick or block wall). If going into a plasterboard wall you will need to purchase appropriate wall fixings. Wipe clear all debris from the Tray before referring to the next stage.
4. Place a bead of Bathroom Sealant (not supplied) the width of the Wall Profiles between the tiled wall and tray. Fit Screw Bases to the 40mm screws (supplied) and secure the Wall Profiles to the wall. Do not over tighten the screws into the Wall Profiles as this will misshape the Wall Profiles. Ensure the Wall Profiles stay completely vertical throughout this procedure using a Spirit Level.
  - **No sealant should be present between the Wall Profiles and the tiled walls vertically prior to screw fixing.**
5. Seal the gap between the Tray and Wall Profile with a Bathroom Sealant (not supplied).
  - **Failure to carry out Stages 4 & 5 can result in serious water damage and is not covered by the Guarantee.**

## Step 3 - Building the Panels

**NOTE:** This part of the installation requires 2 people and a clear area in front of the shower tray in which to assemble the product prior to it being installed. This a view of the inside of the enclosure.

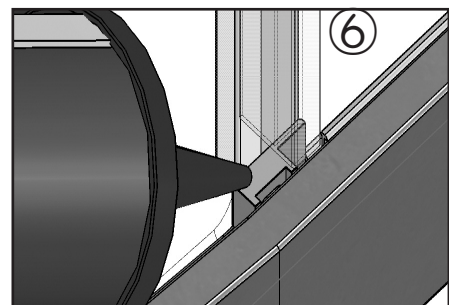
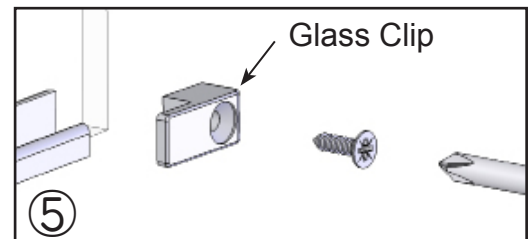
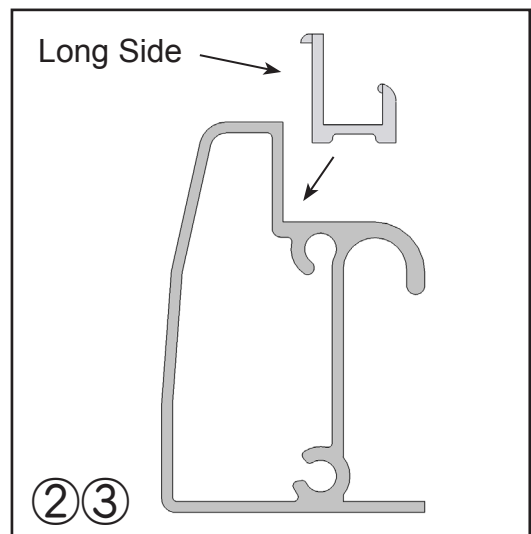
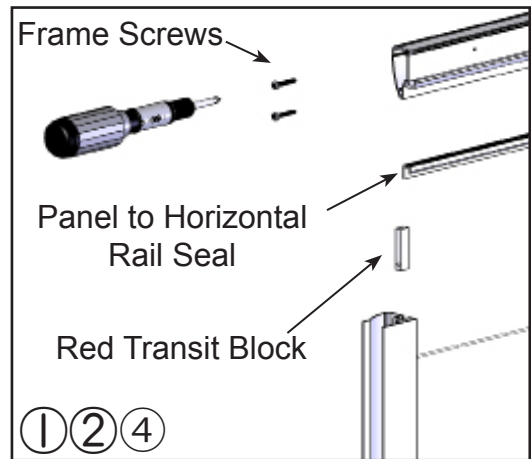

1. **IMPORTANT:** Before proceeding with this assembly remove the Red Plastic Transit Blocks from the top and bottom of the Panel Assemblies and discard.
2. Place the Panel to Horizontal Rail Seals onto the top and bottom of the Panel Assemblies.
3. Make sure that the seals are placed onto the glass the correct way round with the long side running vertically up the glass. The seals must also be pushed fully up to the vertical aluminium extrusion bonded onto the glass.
4. With the seals positioned correctly on the glass, fix the Horizontal Rails to the Panel Assemblies using the screws (Supplied).
5. Secure the glass to the Horizontal Rails by tightening the glass clips, being careful not to overtighten.
6. Seal the gaps in the Glass Clips with silicon sealant to prevent leaking from this area.

## Step 4 - Fitting the Panels

**NOTE:** This part of the installation requires 2 people.

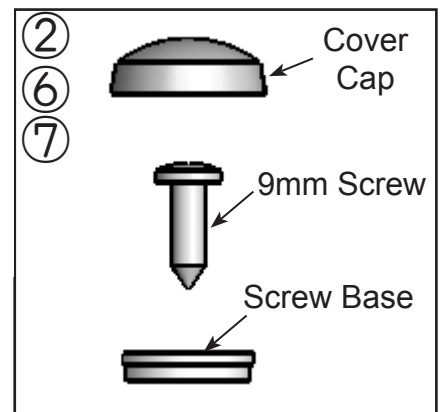
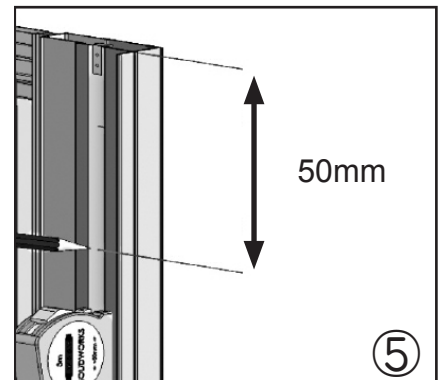
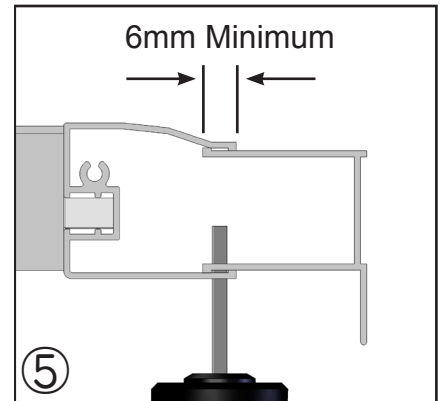
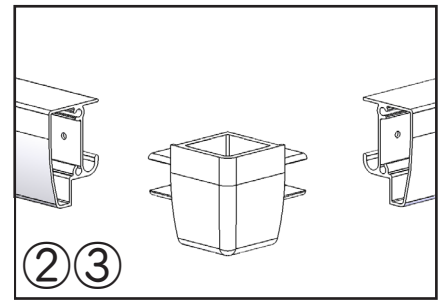
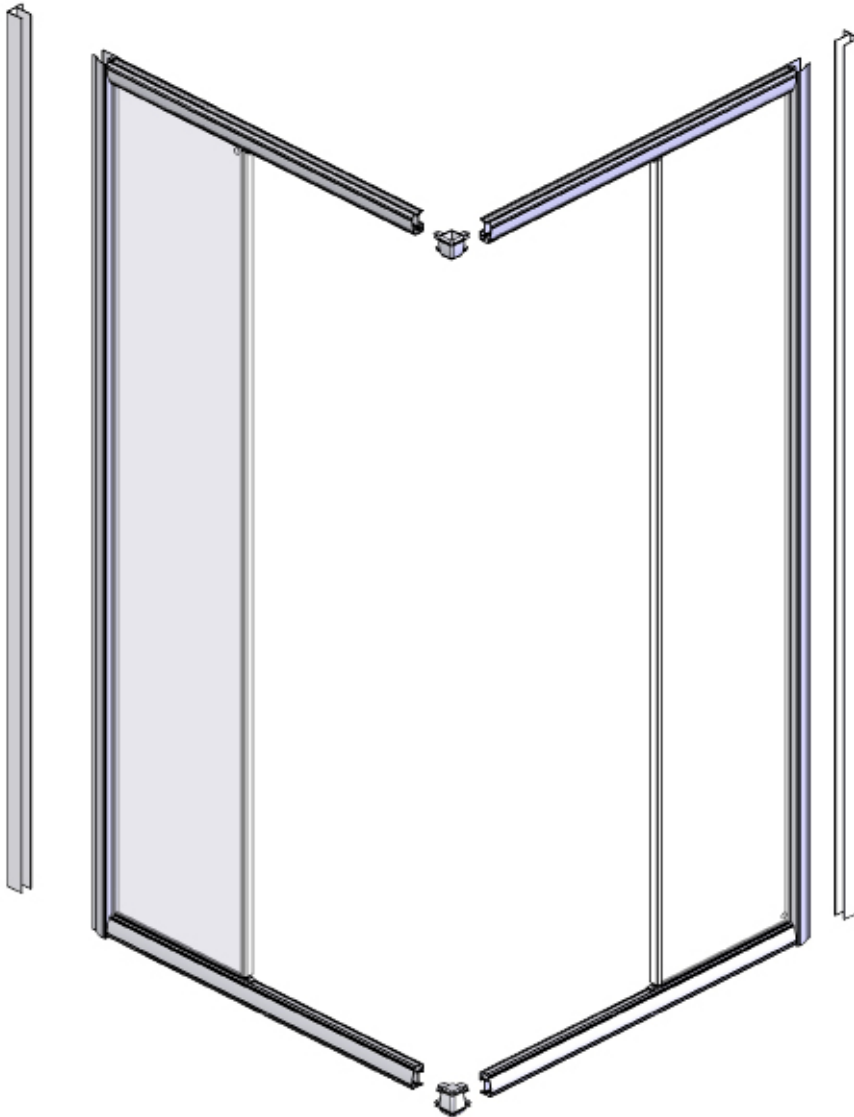

1. Lift each Panel onto the tray and over the Wall Profiles.
2. Place the Corner Mouldings into the Top and Bottom Rails and bring the Panels together.
3. Drill through the Top and Bottom Rails into the Corner Mouldings using a 2.5mm drill bit. Fit screw bases onto two 9mm screws and secure the rails to the mouldings.
4. Position the now joined Panels equally between the Wall Profiles and ensure that they are completely level both horizontally and vertically.
5. Using the 2.5mm drill bit, drill through the Panels Vertical Profile into the Wall Profiles approximately 50mm from each end and the other in the centre.
  - **NOTE:** There should be a minimum of 6mm left for drilling.
6. Fit Screw Bases onto the remaining 9mm Screws and secure the Frames to the Wall Profiles using a screwdriver.
7. Fit all the Screw Cover Caps in the enclosure.

## Step 5 - Assembling the Doors

**NOTE:** The Bearing Assemblies for the top and bottom are different and can be distinguished by the bottom bearings having a domed plunger.

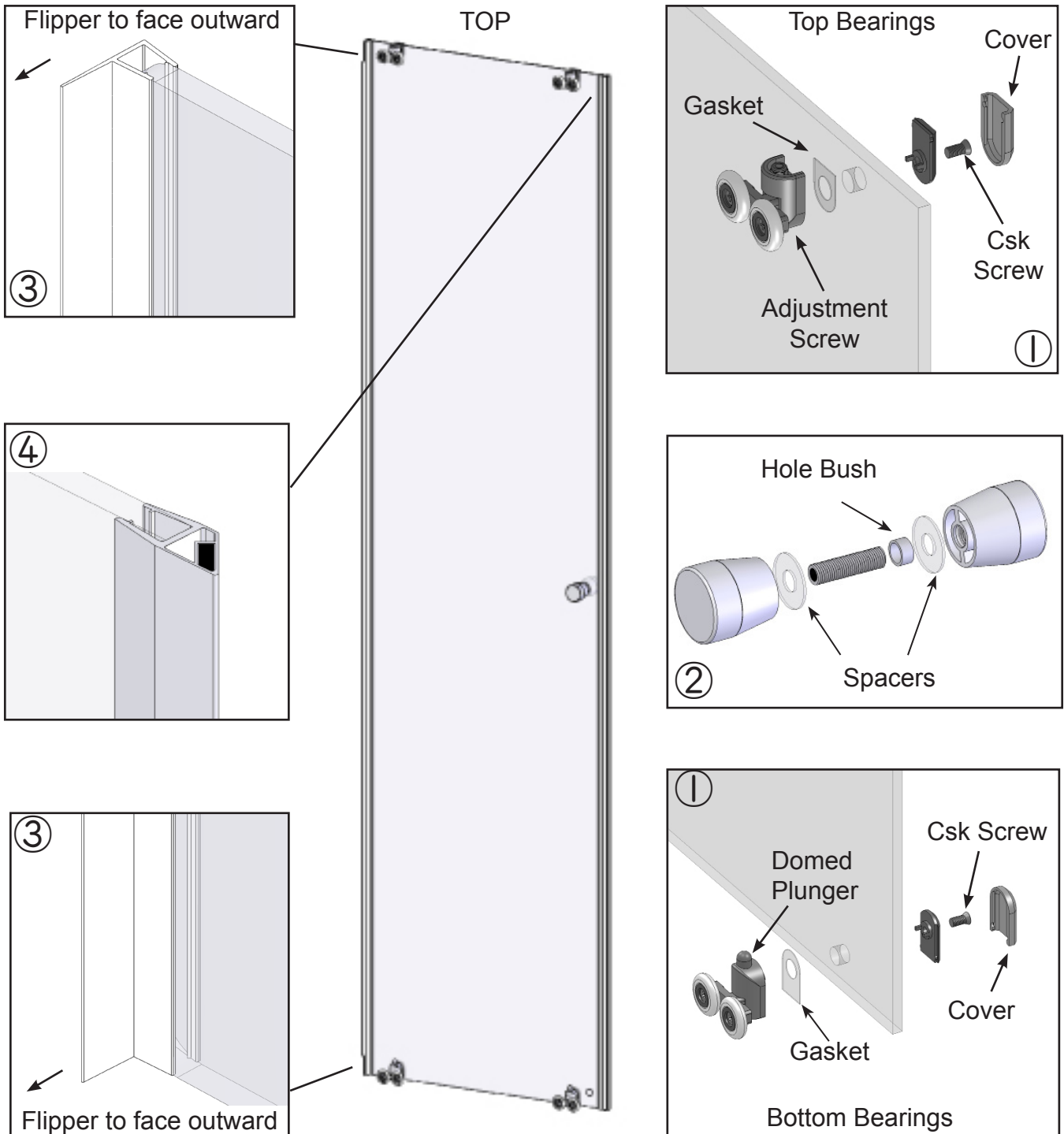

- Carefully dismantle the Bearing Assemblies, place the gasket on the outside of the glass (Bearing Side) then re-assemble onto the Door Glass. Make sure you have the correct bearings at the top and bottom and that the wheels are on the outside of the glass.
  - IMPORTANT:** Fit the Bearing Assemblies to the door using a hand screwdriver only (DO NOT use a Drill).
  - NOTE:** The bottom bearings have a domed plunger.
- Dismantle the Handle Assemblies and re-assemble onto the Door Glass. Make sure the Hole Bush is fitted between the screw and glass and the Spacers are fitted each side of the Door.
- Fit the Vertical Door Seals to the Door Glass, the soft flipper section to face the outside.
- Fit the Magnets to the Handle side of the Door Glass .

## Step 6 - Fitting the Doors

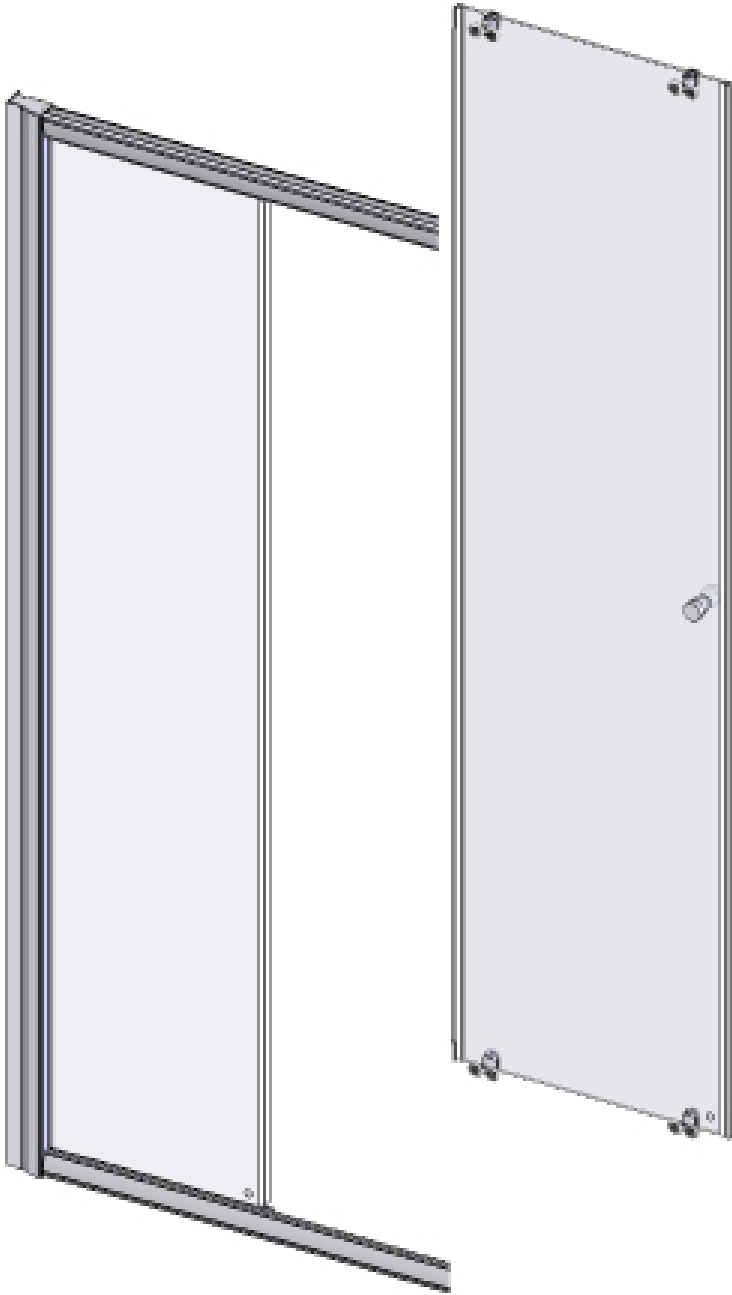

Offer Door at an angle

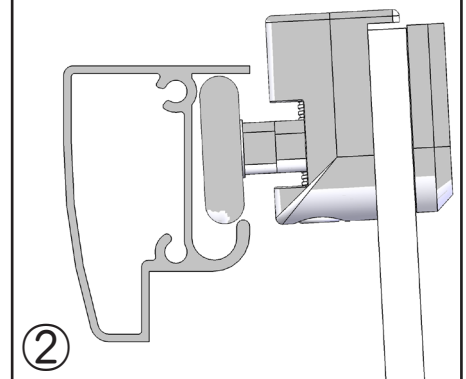

1. Carefully lift the assembled doors into the enclosure ensuring that they are the correct way round.
2. Position the top Wheel Bearings into the Horizontal Top Rails (you may need to have the Doors at a slight angle) and drop the Doors gently down.
3. Push down the spring loaded Domed Plungers on the bottom Wheel Bearings and push under the Horizontal Bottom Rails.

## Step 7 - Door Adjustment and Sealing

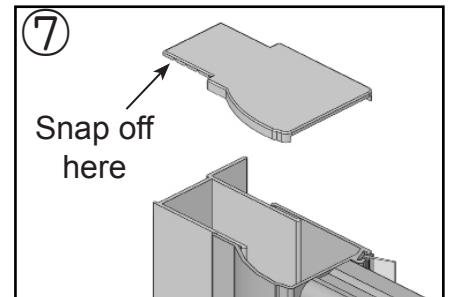
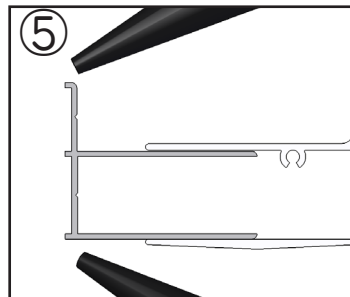
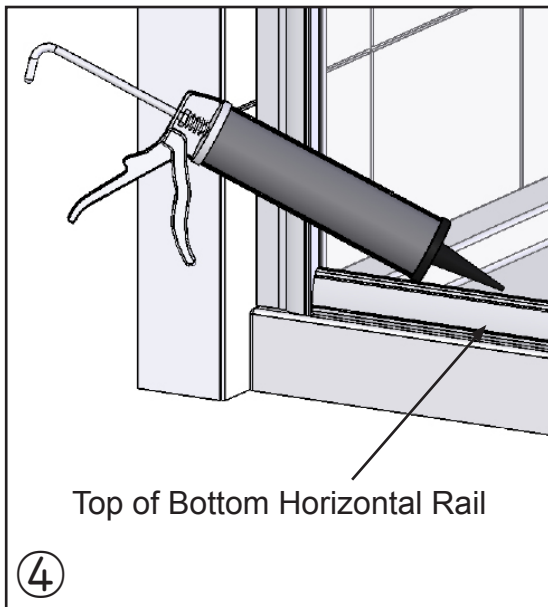
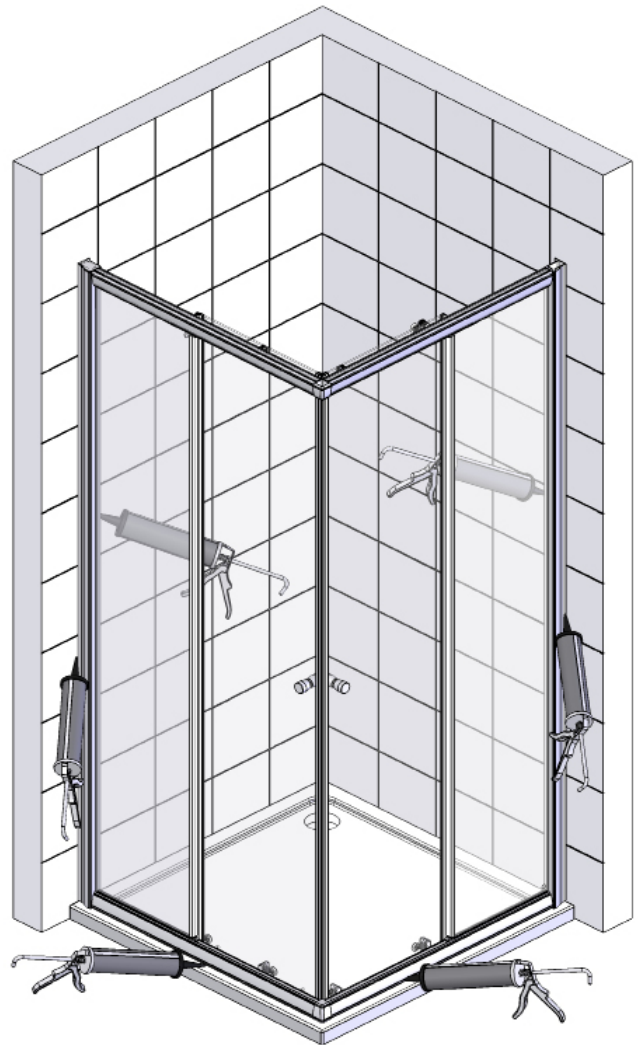
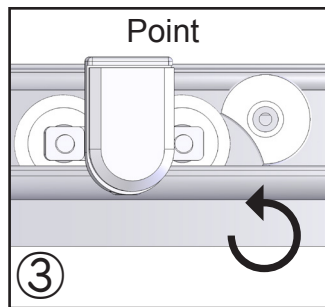
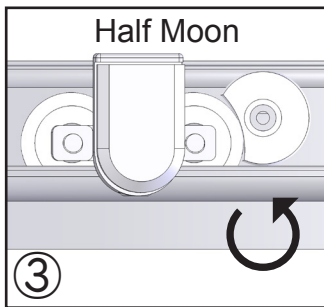
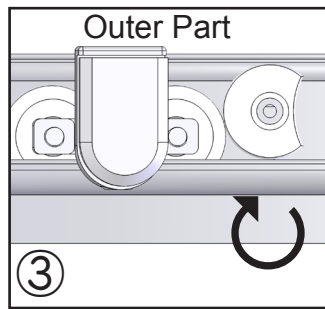
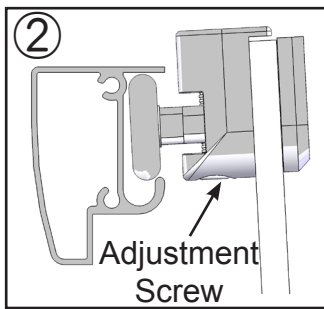

1. Close the Doors and check the Magnets meet each other along the full length, also check that the Doors are running smoothly. The Magnets can be pulled away from the glass slightly to help with the door closure.
2. The Doors can be adjusted by turning the Screws on the Top Bearing Assemblies using a screwdriver. Turn the screws up or down until you are satisfied with the Door.
3. With the Doors adjusted rotate the Door Stops until they just make contact with the wheel of the bearings, this to prevent excessive movement and rocking. The Door Stops can be rotated so that the wheels contact either the outer part, the half moon section or the point (see diagrams).
  - **IMPORTANT: Adjust the Door Stops top and bottom, failure to do so may result in breakages.**
4. Fully seal horizontally between the top of the Bottom Horizontal Rail and the Panel Glass on the outside.
5. Seal both sides of the Wall Profiles vertically inside and outside where they meet the tiled Walls.
6. Fully seal the Bottom Horizontal Rail to the top of the tray on the outside only from wall to wall.
  - **IMPORTANT: Failure to carry out stages 4,5 and 6 may result in serious water damage and is not covered under the terms of the guarantee.**
  - **DO NOT seal the base of the product to the inside, failure to comply may result in the product leaking.**
7. Fit the Top Caps, these can be shortened to fit by snapping off at the relevant groove. Apply a small amount of silicon to the underside to help keep in place
8. Please allow 24 hours for the sealant to cure prior to using the enclosure.
9. Place the branding badge in a prominent position on a none moving part of aluminium.



## Spare Parts

If you need to replace any damaged parts please see illustration below for parts list then call Customer Relations on 01325 328033

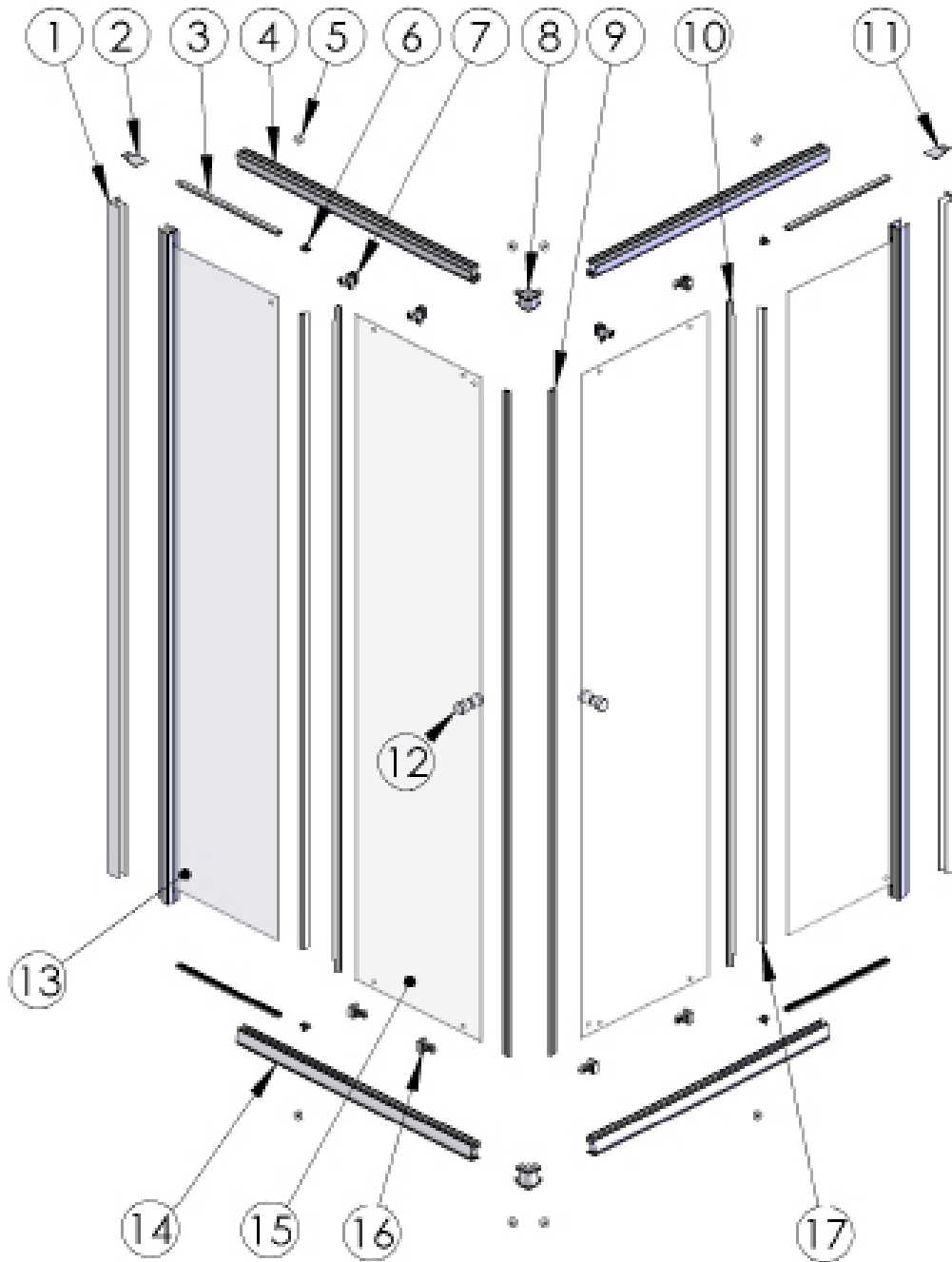

Part No.	Description	Q'ty	Part No.	Description	Q'ty	Part No.	Description	Q'ty
1	Wall Profiles	2	11	Top Cap (Right Hand)	1	21		
2	Top Cap (Left Hand)	1	12	Handle Assemblies	2	22		
3	Panel to Rail Seals	4	13	Panel Assemblies	2	23		
4	Top Rails	2	14	Bottom Rails	2	24		
5	Door Stops	8	15	Door Glass	2	25		
6	Glass Clips	4	16	Bearing Assemblies (Btm)	4			
7	Bearing Assemblies (Top)	4	17	Vertical Panel Seals	2			
8	Corner Mouldings	2	18					
9	Angled Door Magnets	2	19					
10	Vertical Door Seals	2	20					

## TROUBLE SHOOTING GUIDE

Problem	Solution
<b>Leaking</b>	<ol style="list-style-type: none"><li>1. Check that the inside gap between the Tray and Wall profiles has been sealed correctly.</li><li>2. Ensure the tray is sealed along the tiled walls prior to installation.</li><li>3. If the inside joint between the enclosure and the tray top is sealed, this will cause leakage - sealant must be removed.</li><li>4. Ensure the wall profiles on the tiled walls are sealed both vertically inside and outside.</li><li>5. Ensure the Panel Glass and the top of the Bottom Horizontal Rails are sealed horizontally.</li><li>6. Ensure the joint between the enclosure and tray top is sealed.</li><li>7. Ensure the Door Magnets meet fully all the way down.</li></ol> <p><b>Important: This enclosure should be water tested conforming to BS EN 14428</b></p>
<b>Enclosure Alignment on the Tray</b>	<ol style="list-style-type: none"><li>1. Is the enclosure fitted onto a tiled wall?</li><li>2. Are the wall profiles fitted 10mm from the outside of the tray?</li><li>3. Are the wall profiles completely vertical?</li></ol>
<b>Door not running Smoothly</b>	<ol style="list-style-type: none"><li>1. Ensure both wall profiles are completely vertical.</li><li>2. Ensure the tray is completely level.</li><li>3. Ensure the enclosure has an equal gap around the tray.</li></ol>
<b>Door Alignment</b>	<ol style="list-style-type: none"><li>1. Ensure both wall profiles are completely vertical.</li><li>2. Ensure the tray is completely level.</li><li>3. If the door is not aligned correctly, you have adjustment in the top wheel assemblies</li><li>4. Rotate the Door Stop to prevent rocking.</li></ol>

### Some important information to help you Maintain your product.

The following information is all you need to keep your product looking new.

Clean your product using a mild detergent diluted in water and then polished off using a soft cloth. If you live in a hard water area, periodically clean your product using a 50/50 solution of white vinegar and water. The solution should be left on the enclosure for approximately 5 minutes then rinsed off using warm water. This method of cleaning should remove lime scale residue.

### Simple Maintenance

Our products are generally maintenance free, however it may be necessary to lubricate wheel assemblies and other moving parts from time to time.

It is strongly recommended that a quality silicone spray is used.

### A list of Don't's:

1. Don't use acidic based products which are unsuitable for cleaning enamel surfaces.
2. Don't use abrasive cleaners or cleaners using bleach or solvents, these products will adversely affect the finish of the aluminium profiles.
3. Don't use scouring pads, powder or any sharp instruments when cleaning the enclosure.

Should you experience any problems during installation please refer to the Trouble Shooting Guide or contact Customer Relations on:

**+44 (0) 1325 328033**

To enable customer relations to provide you with an excellent level of service it is important that you quote your product Code and Reference Number - these can be found on the Guarantee card.