

TRADE
INSTINCT®

550mm BASIN

BOX CONTENTS:

- 550mm BASIN

FEATURES:

- ONE TAP HOLE OR TWO TAP HOLE
- CHROME EFFECT OVERFLOW RING

PRODUCT CODE:

- INSTWHSQ55BA1 | INSTWHSQ55BA2

WEIGHT: 13.3kg

CE MARK:

- DOP WBVC1 | 19
EN14688-CL10 | PH

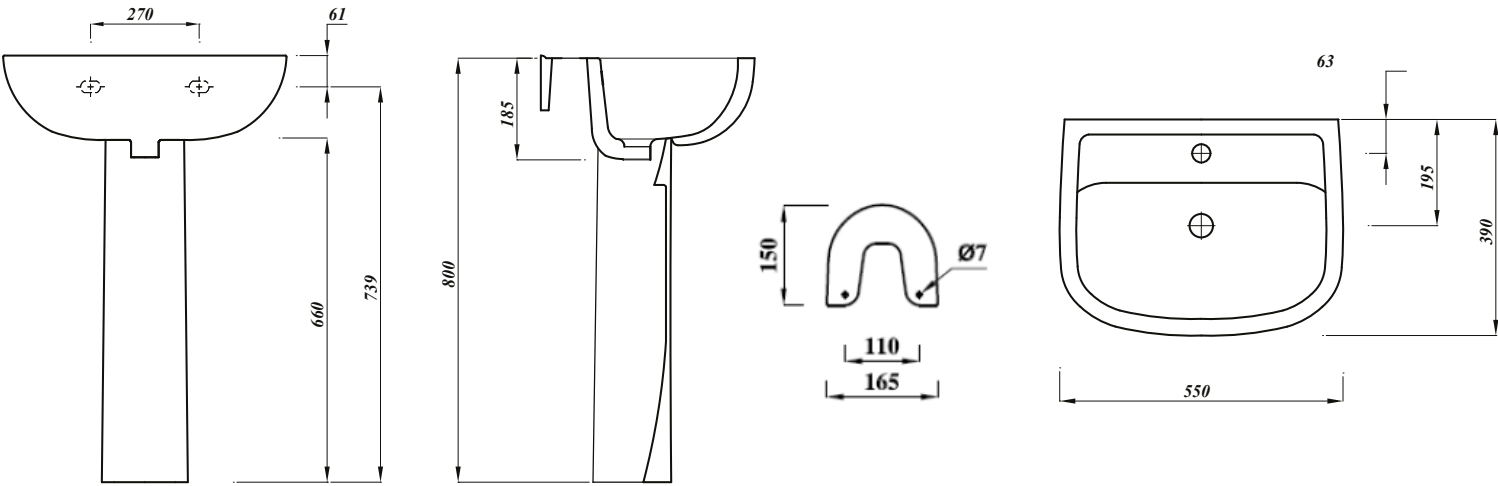

Although every effort is made not to change the above product specification, we reserve the right to do so without prior notification if necessary.