

# TRADE

## INSTINCT®

### COMFORT HEIGHT ROUND CLOSE COUPLED WC SET

#### BOX CONTENTS:

- CLOSE COUPLED PAN
- CLOSE COUPLED CISTERN
  - PRE INSTALLED PUSH BUTTON FITTINGS
- SOFT CLOSE SEAT

#### FEATURES:

- WRAS APPROVED CISTERN FITTINGS
- 6/4LTR DUAL FLUSH
- ADJUSTABLE DOWN TO 4/2.6LTR

#### PRODUCT CODE:

- INSTCHRDSSET

#### WEIGHT:

- 35.5kg

#### CE MARK:

- DOP WCC1-4 | 18  
EN997-CL1-6/4-VR11+CL2 | PH

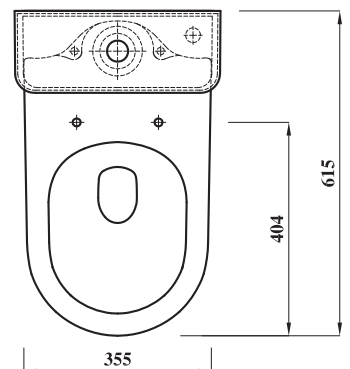
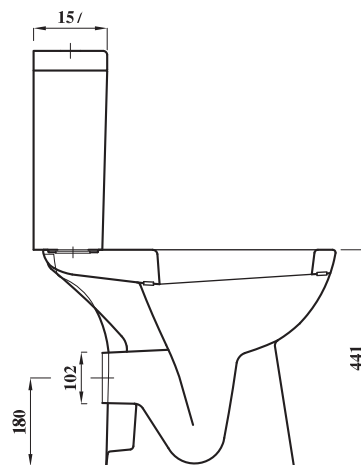
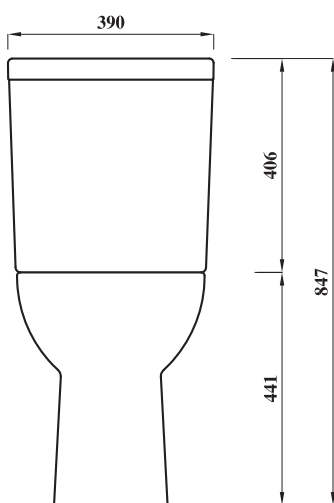

| 140 |