

ALL NEW CLEAR BOWL MAGNETIC SYSTEM FILTER



Features & Benefits

- Effectively filters ferrous and non ferrous system debris
- Specific compact design for small installation footprints
- Transparent settling chamber to easily identify servicing intervals
- 12,000 Gauss, fully removable dry pocket magnet
- 800µm stainless steel filter cartridge for ultimate particle capture
- Multiple inlet/outlet variations to suit any installation requirement
- Direct under boiler connections

Product Range

Description	Part Code
3/4" IntaKlean Nano Magnetic System Filter	IKN34

Multiple inlet/outlet variations

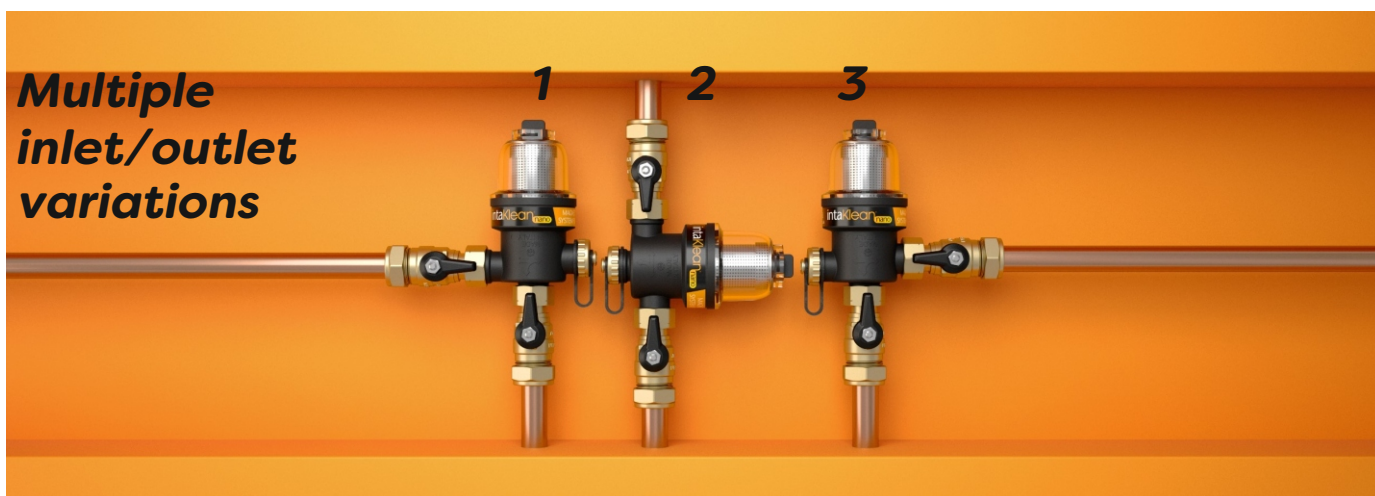

Dimensions

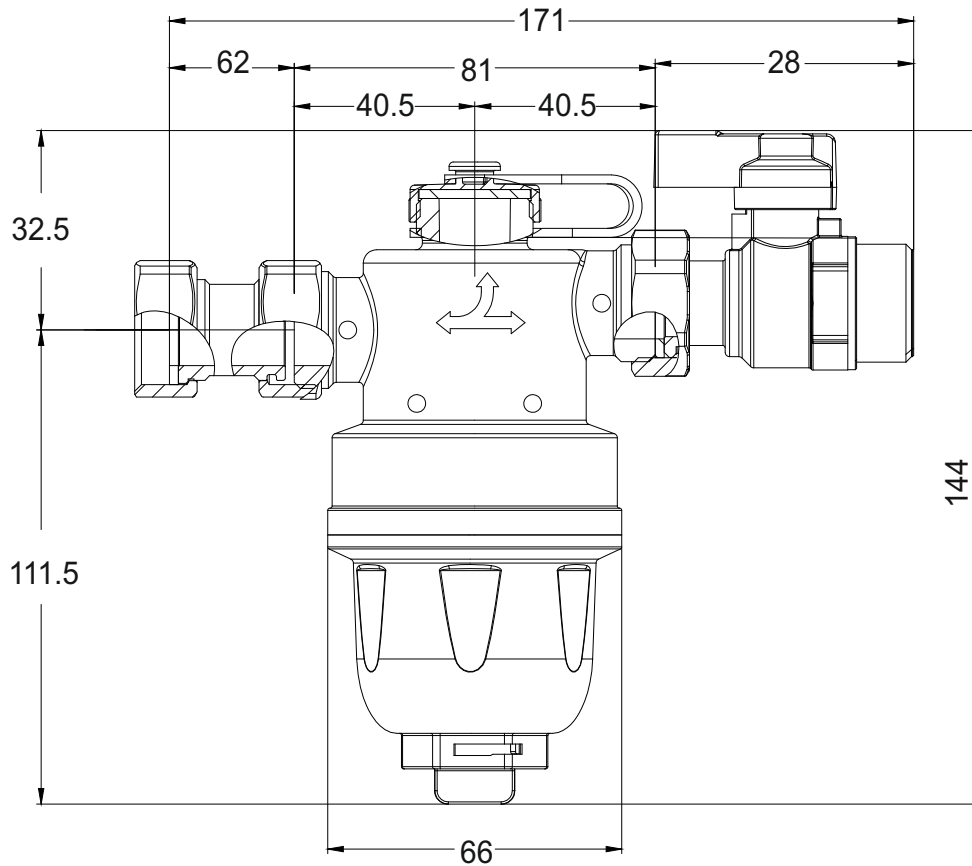

Technical Specification

Maximum Operating Pressure	3 Bar
Maximum Operating Temperature	90°C
Magnet Strength	12,000 Gauss
Compatible Fluid	Water, Water + Glycol 50% Max
Inlet Connection	3/4" BSP