

ALL NEW CLEAR BOWL MAGNETIC SYSTEM FILTER



Features & Benefits

- Effectively filters ferrous and non ferrous system debris
- Specific compact design for small installation footprints
- Transparent settling chamber to easily identify servicing intervals
- 12,000 Gauss, fully removable dry pocket magnet
- 800µm stainless steel filter cartridge for ultimate particle capture
- Complete with isolating ball valves
- Multiple inlet/outlet variations to suit any installation requirement

Product Range

Description	Part Code
22mm IntaKlean Nano Magnetic System Filter	IKN22

**Multiple
inlet/outlet
variations**

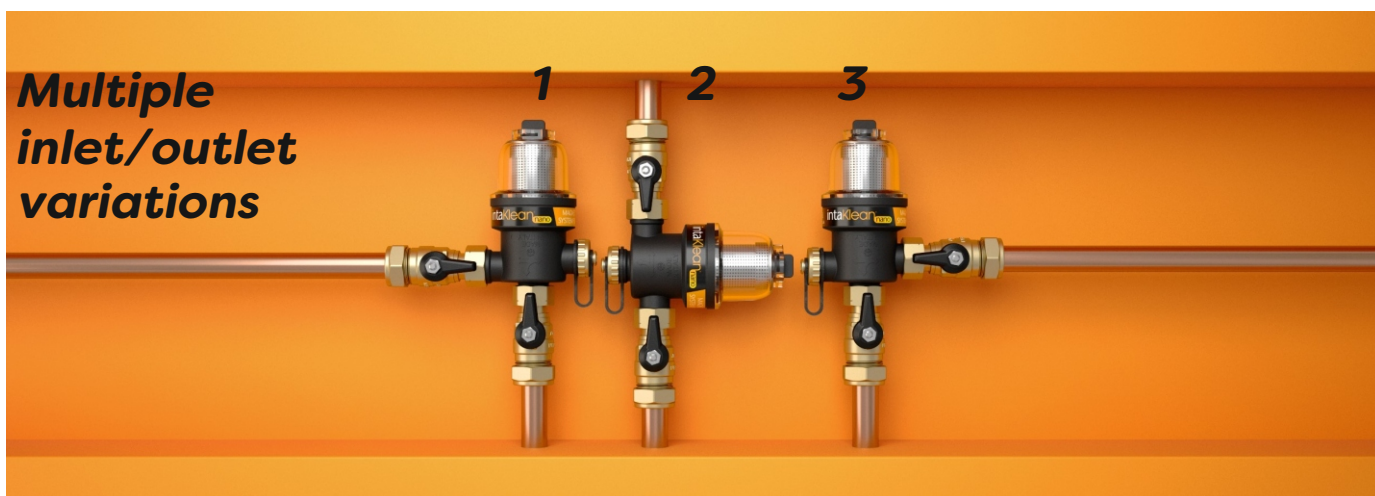

Dimensions

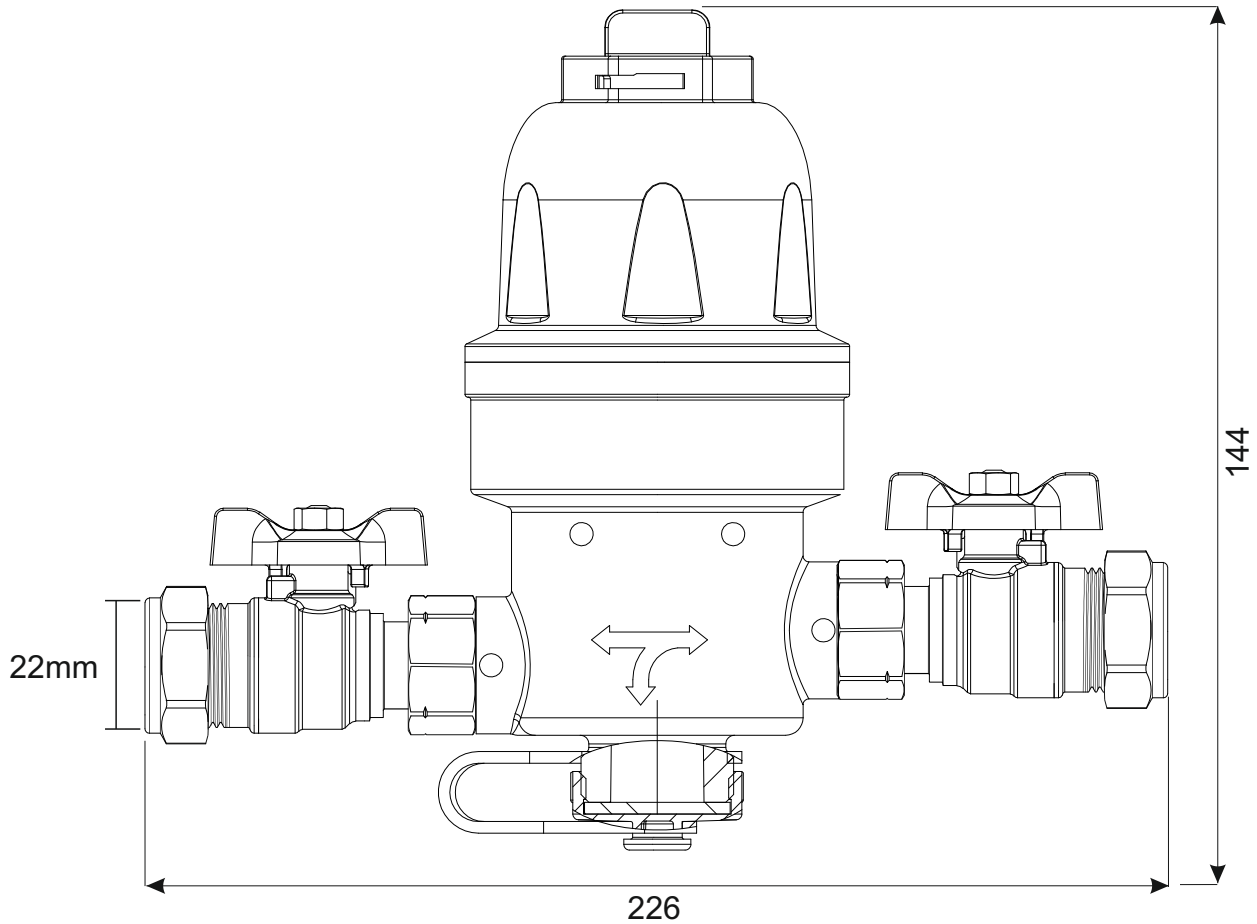

Technical Specification

<i>Maximum Operating Pressure</i>	<i>3 Bar</i>
<i>Maximum Operating Temperature</i>	<i>90°C</i>
<i>Magnet Strength</i>	<i>12,000 Gauss</i>
<i>Compatible Fluid</i>	<i>Water, Water + Glycol 50% Max</i>
<i>Inlet Connection</i>	<i>22mm Compression</i>