

Hemsworth Lever Twin Outlet Thermostatic Bar Shower Mixer INSHE3034

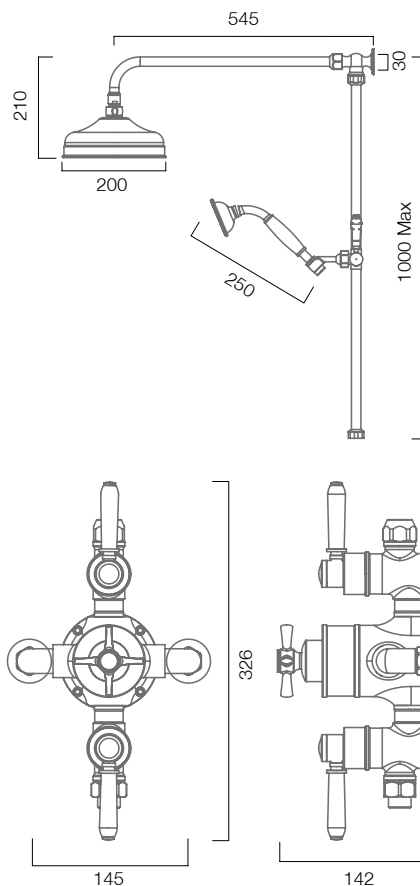

Specification

Finish	Chrome
Dimensions	1325(h) x 200(w) x 600(d) mm
Weight	4.7kg
Body Material	Brass
Hose Material	Stainless Steel
Hose Length	1500mm
Hose Connection	G½" Thread
Hose Bore	10mm
Overhead	Adjustable
Overhead Material	Brass
Overhead Size	200mm
Shower Arm Length	545mm
Handset Material	Brass
Handset Functions	Single Function
Valve Inlet Centres	150mm
Valve Connection	15mm / ½" Thread
Valve Handle Material	Brass
Min Operating Pressure	1 Bar
Max Operating Pressure	6 Bar
Max Static Pressure	10 Bar
Max Operating Temperature	43°C
Thermostatic Safety Stop Setting	42°C
Flow Restrictor	No

Flow Rates

Pressure	0.2	0.5	1	3
L/min	-	-	9.6	21.9

All Pressures in Bar. All flow in L/Min. Dimensions supplied are nominal and subject to tolerance. Inclusion or restrictors (sold separately unless stated) will affect flow rate result. Performance details are based on trials under test conditions and for guidance only. The Company reserves the right to change product specification without prior notice.

Key Features + Benefits

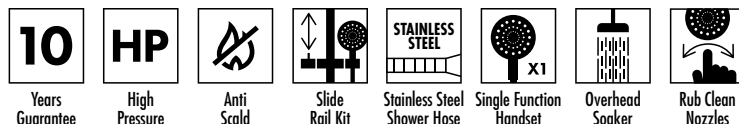

Certifications + Approvals

Flow Rate – 9.6 l/min

Tested at 1 Bar

Roper Rhodes

Brassmill Lane Trading Estate, Bath, BA1 3JF. Technical Support – Tel: 01225 303 900 Email: sales@roperrhodes.co.uk

All information on the data sheet is correct at the time of publication. All measurements are approximate and subject to standard tolerances.