

Hemsworth Classic 500mm Ceramic One / Two Taphole Basin INST041301, INST041302



Specification

Finish	White
Dimensions	187(h) x 517(w) x 390(d) mm
Weight	9.8kg
Basin Material	Ceramic
Overflow	Yes
Chainstay Hole	Yes (INST041301) No (INST041302)
Reversible	-
Taphole Positioning	Centre

FAQs

Please see next page

One Taphole Basin

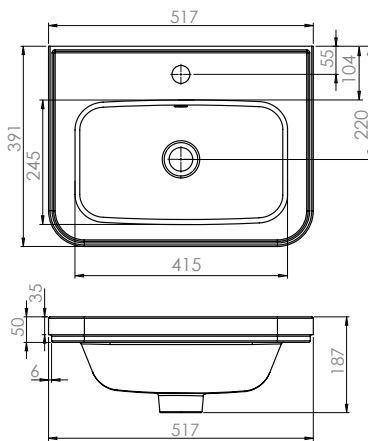

Two Taphole Basin

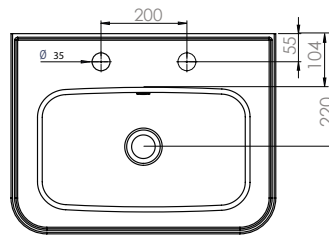

Key Features + Benefits

5

Years
Guarantee



One Taphole
Basin



Two Taphole
Basin

Certifications + Approvals

Roper Rhodes

Brassmill Lane Trading Estate, Bath, BA1 3JF. Technical Support – Tel: 01225 303 900 Email: sales@roperrhodes.co.uk

All information on the data sheet is correct at the time of publication. All measurements are approximate and subject to standard tolerances.

Technical Data Sheet | Modular Furniture

www.instinctproducts.co.uk

Hemsworth Classic 500mm Ceramic One / Two Taphole Basin INST041301, INST041302

FAQs

Q – What is the maximum water depth of the basin?

A – 82mm up to the overflow.

Q – What is the width of the Tapledge?

A – The Tapledge is 104mm wide.

Q – What is the distance from the Taphole centre to Basin Waste?

A – One Tap Hole: 165mm. Two Tap Hole: 155mm

Q – Can this basin be wall mounted?

A – No.

Q – Does the basin fit other furniture?

A – Yes, this basin is also compatible with the Los range.

Q – What are the taphole/basin waste sizes?

A – All sizes are to British Standard - (BS EN 31)

– Diameter of the central taphole = 35mm : +2/ -1mm

– Bore of the waste outlet hole = 46mm : +2 / - 3mm

– Diameter of the base for the seal between the waste outlet hole and the waste fitting = ≥ 60 mm