

Dual 1200 x 600mm Towel Rail (Heating Only) DU12060CP



Specification

Finish	Chrome/White
Dimensions	1200(h) x 600(w) x 104(d) mm
Weight	19.7kg
BTU Output/Hr	3992
Watts @ $\Delta T50^{\circ}C$	1170
Bars	25
Pipe Centres	555mm
Electric Element Wattage	-
Face to Face Connections	-
Radiator Columns	-
Material	Mild Steel

All heat outputs are shown at $50^{\circ}C \Delta t$ in compliance with BSEN442. Watts and Btu's apply to Heating and Dual Fuel only.

Key Features + Benefits



15
Years
Guarantee

MS
Mild
Steel

Certifications + Approvals

Technical Data Sheet | Designer Towel Rails

Dual 1200 x 600mm Towel Rail (Heating Only) DU12060CP

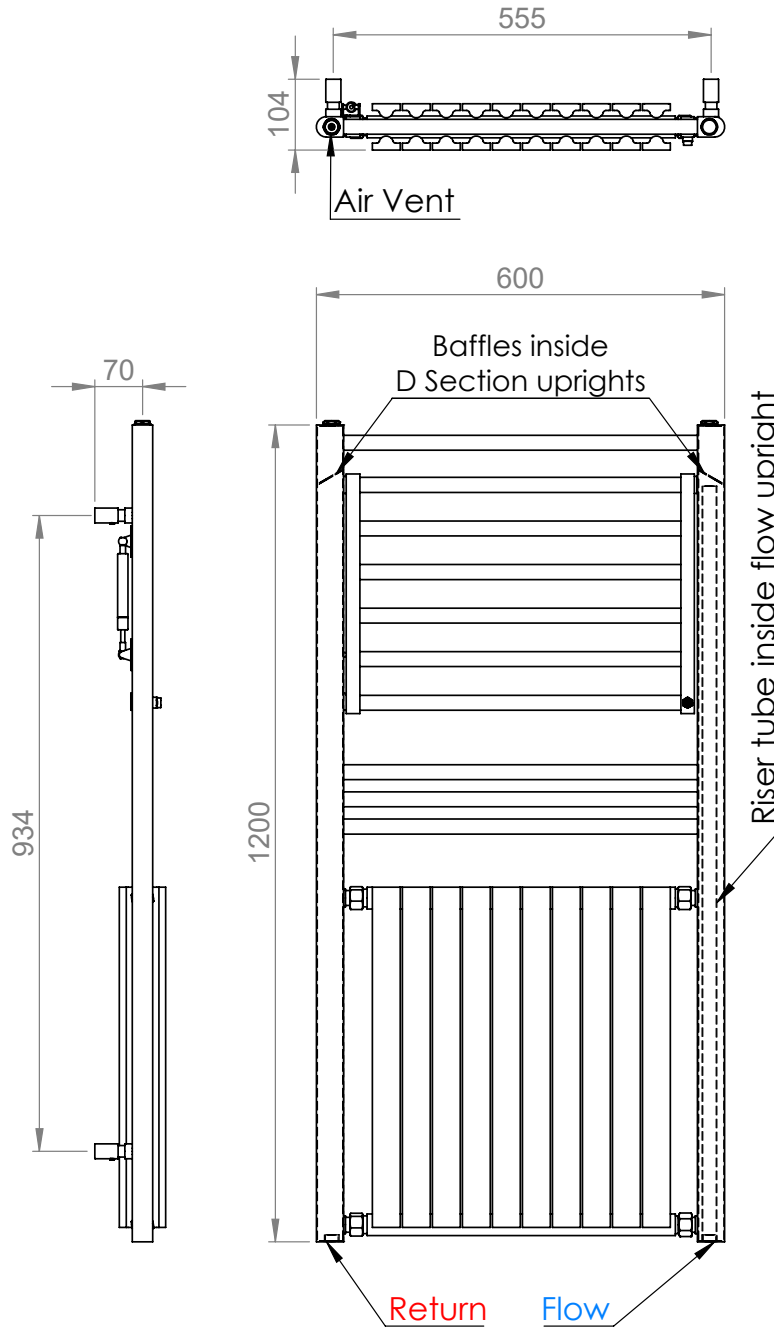

*Dual energy models require a conversion-tee, consult relevant drawing for details.