

Technical Data Sheet | Condensate Removal Pump

www.instinctproducts.co.uk

Condensate Removal Pump SI83CE05IN23



Specification

| | |
|----------------------------------|---|
| Finish | White |
| Dimensions | 129(h) x 287(w) x 146(d) mm |
| Weight | 1.83kg |
| Tank Capacity | 2 Litres |
| Mains Supply | 230 V~50 Hz - 115W-1.4 A |
| Max Discharge Head | 5.4m (65 l/h) |
| Max Pressure (Flow Rate 0) | 5.7m |
| Sound Level in Application at 1m | ≤ 45 dBA (Measured in Sauermann acoustic lab, pump operating with water) |
| Max Condensate Temperature | 55°C, 80°C Short peaks 10 minutes |
| Max Condensate Acidity | pH > 2.5 (Gas condensing boilers) |
| Safety switch | NC |
| Thermal protection (overheating) | 120°C (Auto reset) |
| Operating conditions | 7%: 16s ON - 212s OFF |
| Class | I |
| IP Rating | IP44 |
| Safety standard | CE |
| RoHS directive | Compliant |
| WEEE directive | Compliant |

Applications

- Residential applications
- Air-conditioning up to 20kW
- Heating up to 40kW
 - Gas condensing boiler
 - Condensing high efficiency gas furnaces

Key Features + Benefits

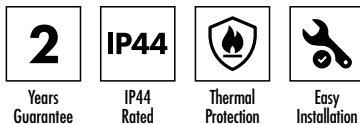

Certifications + Accreditations

Sauermann UK

Units 7-9 Trident Business Park, Amy Johnson Way, Blackpool FY4 2RP. Technical Helpline: 01253 340170 Email: info.uk@sauermanngroup.com

All information on the data sheet is correct at the time of publication. All measurements are approximate and subject to standard tolerances.

Condensate Removal Pump SI83CE05IN23

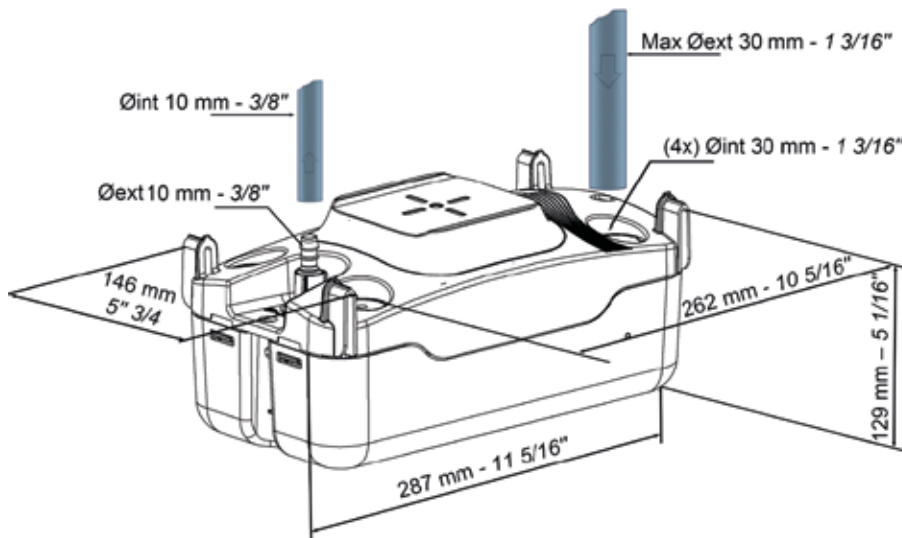

Features

Exceptional Durability and Reliability

- Float design resistant to fouling
- Stainless steel motor shaft
- Tolerates acidic condensates (pH >2.5) produced by gas-condensing boilers

Quick + Easy Installation in any place

- Designed for intuitive installation
- Can be floor-mounted, wall-mounted, or suspended from the ceiling
- Can be easily installed whatever the lay out of the premises thanks to its very compact profile: 129mm in height
- 5 inlet options for unmatched versatility Ø 30mm: 4 on top, 1 on the side for low condensate entry
- Rod mounting system makes levelling easy
- Customized Smartphone App (available for both iOS and Android devices)

Quick + Easy Maintenance

- No need to remove pump from installation to clean
- Removable anti-return valve
- Maintenance function in the Smartphone App (available for both iOS and Android devices)

Regular Duty

- IP 44
- 2 Litre tank capacity

Kit Contents

- One-piece centrifugal pump with 2 Litre tank
- Integrated barb end check valve, Ø ext. 10mm
- 1.8m power cord, plug
- Straight connector, diameter 10mm
- Rubber outlet adaptor, diameter 10mm (3/8) - 20mm (3/4)
- Clear PVC tubing int. diameter 10mm, 6m long
- Built-in safety switch, 1m wires, plug, NC
- 2 screws, 2 plugs

Accessories

- | | |
|--------------------|--|
| ACC00911 | Clear PVC tubing Ø int. 10mm, 25m roll |
| ACC00915 (braided) | 10mm, 25m roll |
| ACC00925 | Non-Return Check valve for Ø ext. 10mm tubes |
| ACC00939 | 3 size multi adaptor to be used for Ø 15/17 - 20 - 24/25 - 32 - 40mm tubes |
| PH0100SIUN23 | Neutralization cartridge to treat condensates produced by gas condensing boilers |

| Condensate Inflow Rate (l/h) | Total tube length using Ø int. 10 mm | | | |
|------------------------------|--------------------------------------|-----|-----|-----|
| | 5m | 10m | 20m | 30m |
| Discharge Head | | | | |
| 1m | 26 | 23 | 17 | 13 |
| 2m | 22 | 19 | 14 | 13 |
| 3m | 19 | 16 | 11 | 8 |
| 4m | 13 | 10 | 7 | 6 |
| 5m | 8 | 6 | 4 | - |

Sauermann UK

Units 7-9 Trident Business Park, Amy Johnson Way, Blackpool FY4 2RP. Technical Helpline: 01253 340170 Email: info.uk@sauermanngroup.com

All information on the data sheet is correct at the time of publication. All measurements are approximate and subject to standard tolerances.