

Broxa Curve H Pattern Bath Shower Mixer & Kit (Two Taphole) 4E6053



Specification

Finish	Chrome Plate
Dimensions	126(h) x 230(w) x 168(d) mm
Weight	2.1 kg
Body	Brass
Fittings	Metal backnut & washer
Connection	¾" BSP Threaded tail
Max Static Pressure	25
Min Dynamic Pressure	0.1
Max Dynamic Pressure	6
Max Water Temperature	65°C

Flow Rates

Pressure	0.1	0.5	1.0	3.0
Flow Aerator	-	-	-	-
Flow Straightener	6.6	15.1	22.1	39.1

All Pressures in Bar. All flow in L/Min. Dimensions supplied are nominal and subject to tolerance. Inclusion or restrictors (sold separately unless stated) will affect flow rate result. Performance details are based on trials under test conditions and for guidance only. The Company reserves the right to change product specification without prior notice.

Spares

Outlet	856119
Headwork Hot	856144
Headwork Cold	856143

The Company is not responsible for the installation of the spares supplied, which must always be fitted by a competent person. Parts supplied are in many cases identical to the original component whilst others are offered as a suitable alternative. All spares listed are suitable for direct replacement unless stated. The Company reserves the right to change product specification without prior notice.

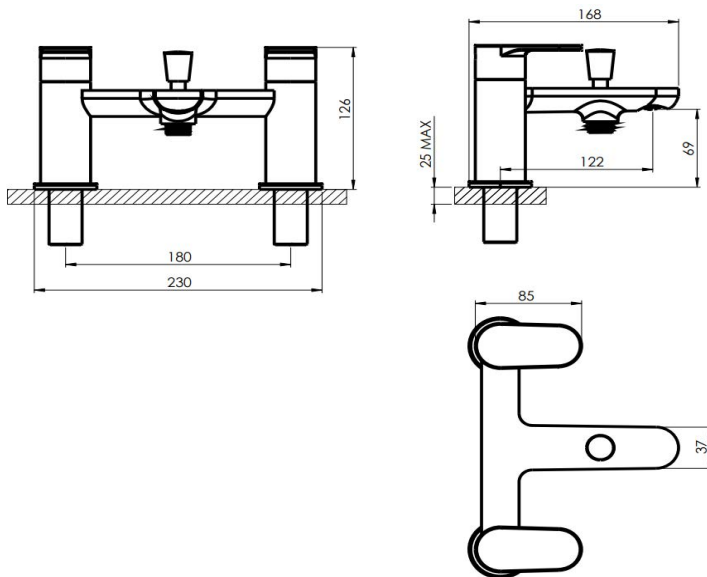

Key Features + Benefits

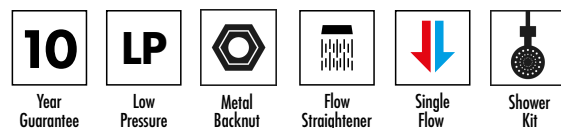

Certifications + Approvals



Tested at 0.2 Bar

StH Westco

Unit C6, William Way, Moss Industrial Estate, St Helens Road, Leigh, Lancashire, WN7 3PT. Technical Support – Tel: 01942 265311 Email: support@francistaps.co.uk

All information on the data sheet is correct at the time of publication. All measurements are approximate and subject to standard tolerances.