

INSTINCT®

**Azerley Thermostatic Twin Outlet
Bar Shower Mixer
Installation Instructions**

www.instinctproducts.co.uk

About Installation

Care must be taken during installation to prevent damage to the product or injury to the installer.

Installation must be carried out by a qualified and competent person, and in accordance with the instructions supplied with the product.

All installations must comply with Local and National regulations.

Please ensure that you have read and understood all sections of this guide BEFORE installation.

Water Regulations

The water supply must be connected in accordance with the water regulations, and good plumbing practice.

We recommend that hot and cold water supplies are at equal pressure, in order to give consistent flow. If this is not possible, non-return valves must be fitted to both supplies in accordance with current Water Regulations. These recommendations apply to both mains and tank fed systems.

Flushing

The water regulations requires fittings to be flushed before first use. We recommend that supplies are thoroughly flushed to remove debris BEFORE making any pipe connection to the tap. Failure to do so could result in damage to the product or unsatisfactory performance.

Water Pressure

Maximum Static Pressure – 10 Bar

Flow Pressure, Hot & Cold – 0.5 Bar - 5 Bar

Temperature Parameters

Hot Supply Temperature – 55°C-65 °C

Cold Supply Temperature – 5°C-25 °C

Prior to Installation

1. Check that the supplied product is correct and complete and has no surface damage
2. Ensure that all existing pipe work has been flushed and that the pipe work is prepared for the installation of your new tap
3. Isolate the water supply by closing the stop cock or isolating valves

Important – Care & Maintenance

1. Surfaces should only be cleaned using a soft non abrasive cloth and clean water. Mild detergent can be used to clean
2. Never use household cleaners which contain bleach or abrasive cleaners

Tools Required

– Protective Cloth

Tape Measure

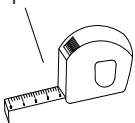

Screw Driver



Electric Drill

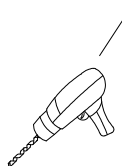

Pen

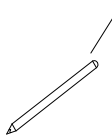

Adjustable Spanner

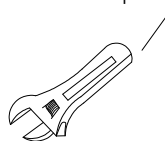

Allen Key

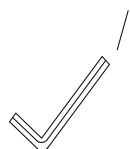

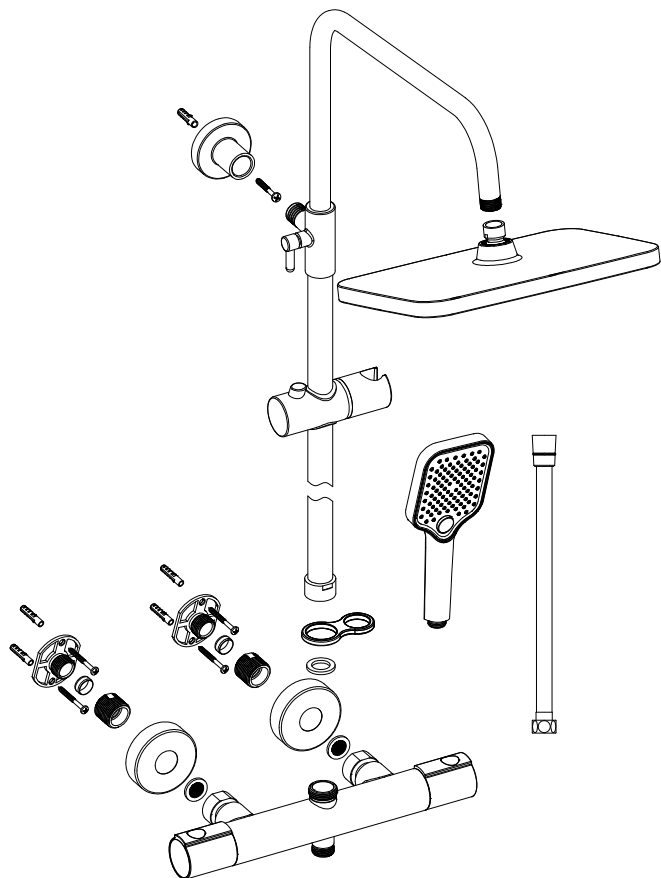
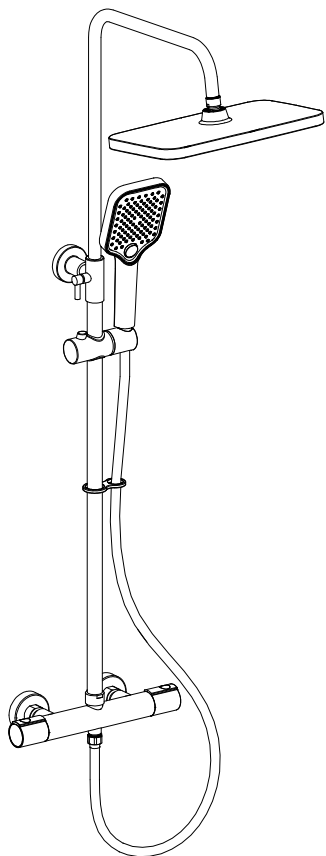

Installation

The valve should be installed in accordance with the water bye-laws. For further details refer to the latest copy of Water Bye-laws guide or your local water authority.

1. Identify all components
2. Prior to installation flush out pipework to remove debris.

Valve

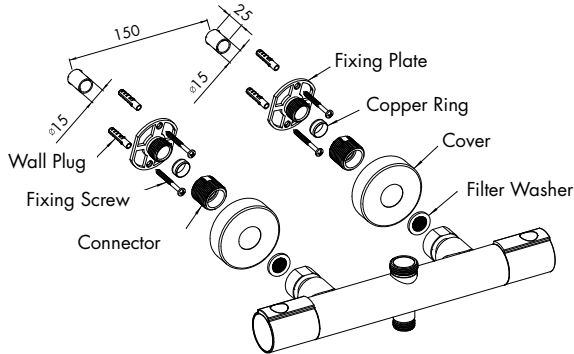

1. Place two fixing plates on hot & cold inlets and mark fixing holes, drill four holes of $\text{Ø}8\text{mm}$ diameter with depth of 45mm.
2. Fix the fixing plates against wall, put in wall plugs and fixing screws with screwdriver. Place copper rings inside the fixing plates, then tighten and seal with connector. Finally put wall covers on and tighten properly.
3. Place filter mesh inside the inlets of bar valve. Fix bar valve to connectors with spanner. Please use a cotton sheet inside of spanner in case of any scratches. Make sure hot inlet on the left and cold inlet on right, otherwise it will affect the performance.

Slider Rail

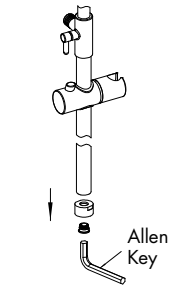
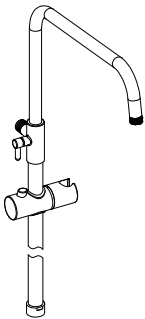

Step 1
Screw off the connector using Allen key.

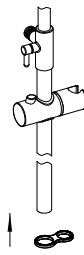

Step 2
Put the hose retainer ring onto the slider rail.

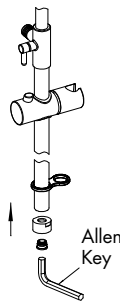

Step 3
Screw on the connector back to the slider rail.

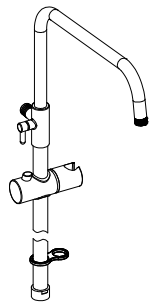

Step 4
Move the adjustable holder to the best position.

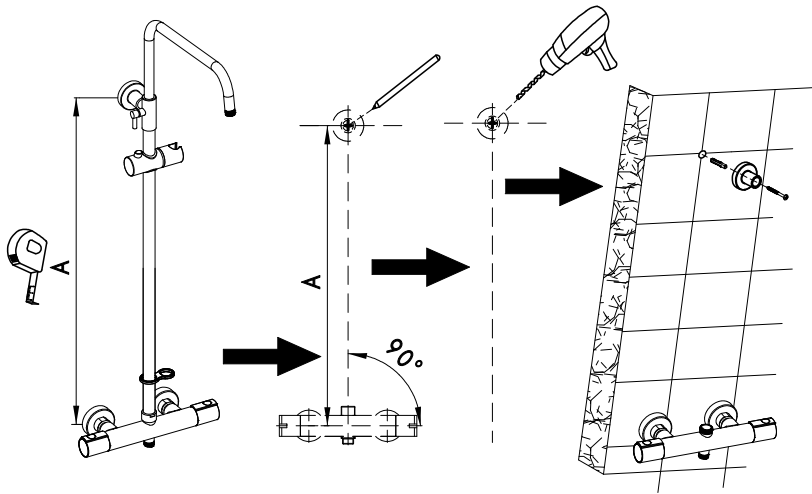

Measure the installation height of the shower kit with tape. Mark two holes in required position with pen. Always check before drilling that no cables or pipes can be

damaged. Drill holes with electric drill and place the wall plugs into the holes. Fix the top bracket to the wall.

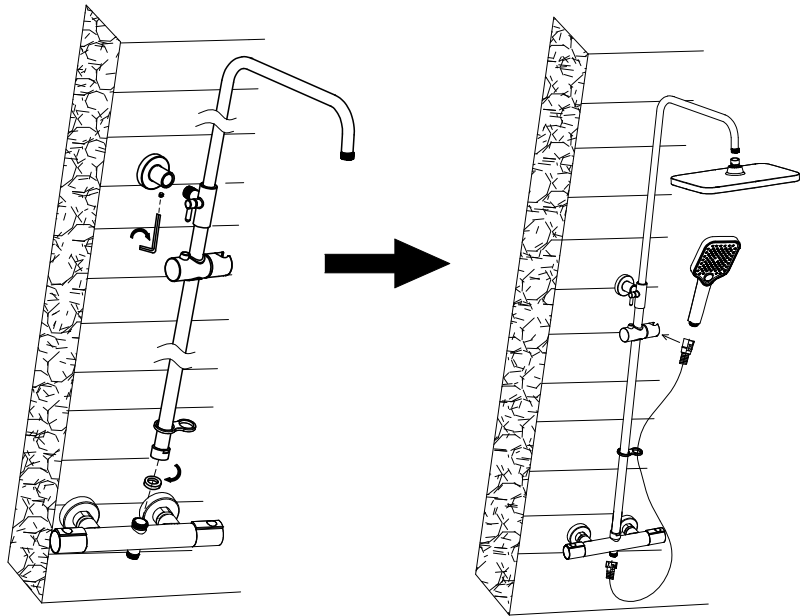

Put the gasket seal into lock nut of sliding rail, assemble sliding rail to mixer body, tighten the lock nut and then assemble the sliding rail to top bracket via fitting screw at base of top bracket, tightening with allen key to secure

slider rail. Connect one end of the shower hose to outlet under body and other end through hose retainer and connect with hand shower. Fix shower head to top of sliding rail.

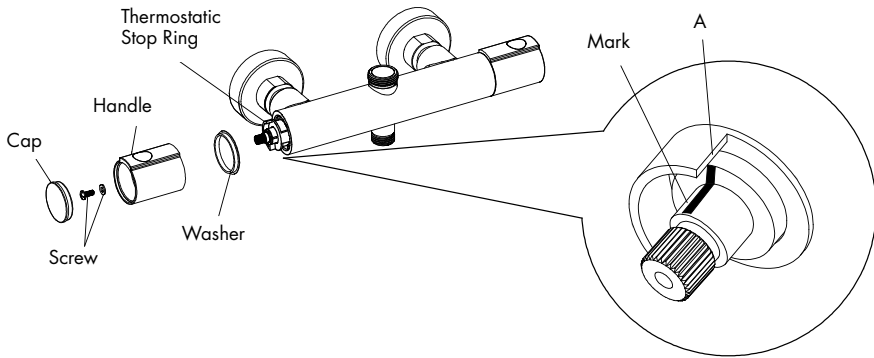

Trouble Shooting

1. **Output water temperature does not correspond with temperature set.**
 Cause – Thermostat has not been adjusted based on the existing home water system.
 Remedy – Adjust the thermostat, refer to 'Temperature Setting' procedure.
 Cause – Hot water temperature too low.
 Remedy – Adjust the water heater, increase hot water temperature to 65°C.
2. **Crossflow, cold water being forced into hot water pipe, or vice versa, when valve is closed.**
 Cause – Non-return valves dirty or leaking
 Remedy – Clean the non-return valves or exchange if necessary.
3. **Very low flow or no flow.**
 Cause – Supply pressure inadequate.
 Remedy – Check hot and cold feeds. If a pump has been installed, please check to see if the pump is working (the valve will shut down if either the cold or hot water supply fails).
4. **Water will not run hot enough when first installed.**
 Cause – Wrong maximum temperature setting.
 Remedy – Adjust the maximum temperature, refer to 'Temperature Setting' procedure.

Temperature Setting

1. Open the handle cap, unscrew the screw with a screw driver, and take off the handle and washer.
2. Check if face A on the stop ring is aligned with the mark on the thermostatic cartridge. If not, make aligned by turning the spindle.
3. After face A on the stop ring is aligned with the mark on the Thermostatic cartridge, reassemble handle, washer and cap.

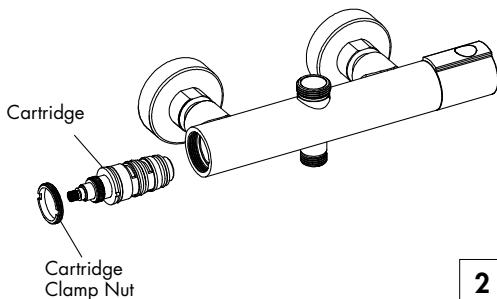
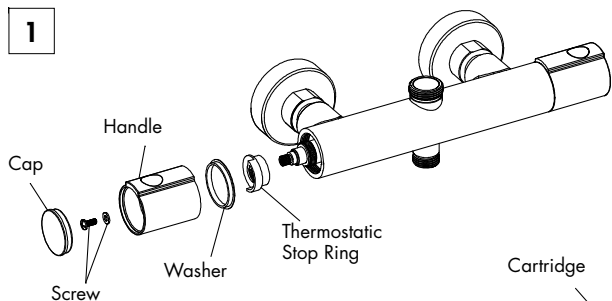
1**2**

Maintenance (Thermostatic Cartridge)

After a period of use of the thermostatic mixer, there will be some waste or debris from the water pipe on and around the thermostatic cartridge, which will affect the flow and sensitivity of the thermostat. Please take out the thermostatic cartridge and clean the cartridge strainer. Before removing any parts please turn off water supply.*

To avoid damage, please remove all chrome parts before any maintenance takes place.*

1. Take off the cap, untighten the screw, to remove handle and washer. Remove the thermostatic stop ring and take note of the position for replacing (See figure 1).
2. Untighten the cartridge clamp nut to take out the cartridge (See figure 2).
3. Wash the cartridge with clean running water, dry and lightly grease the seals (only use silicone grease).
4. Replace the cartridge and make sure it is back to the primary position.

*Cartridge Type – H104P is the spare part number of thermostatic cartridge.

Cleaning

To maintain the surface of your product, wipe with a clean damp cloth and wipe dry. Do not use abrasive cleaning agents or materials which can strip and scratch the surface; the use of these agents or materials can invalidate your guarantee. It is recommended to wipe and dry on a regular basis.

INSTINCT®

Product Support

T: 01355 241111

E: sales@highlifebathrooms.com

www.instinctproducts.co.uk