

# 550 & 700 VANITY UNITS

## INSTALLATION & AFTERCARE INSTRUCTIONS

### Before installation

For floor standing units intended to be attached to the building: **WARNING** in order to prevent overturning this product must be used with the wall attachment device provided.

It is recommended that the unit and basin are secured to a suitably reinforced wall to ensure stability. This can be done through the back rail (fixings not included).

### Fixing Handles

- A pilot hole located at the back of the door can be drilled if using a single screw knob
- If you have chosen a pull handle with 2 screws then please pilot and then drill through the door with the handles in the desired location.
- Carefully drill any holes using a clamped block of wood to protect the front of door - See figure 1.
- The handles can simply be screwed into place using the screws supplied.
- If you choose third party handles please measure carefully before drilling.

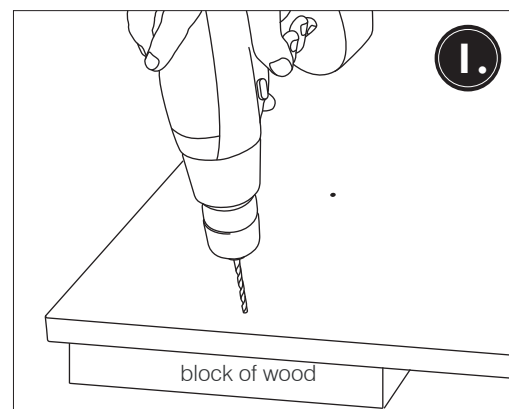

### Door adjustment

The unit doors can be adjusted or removed if necessary. There are two adjustment screws on the hinges which make the adjustments shown in the image below. The quick release button on the back of the hinge can be used to remove the door completely.

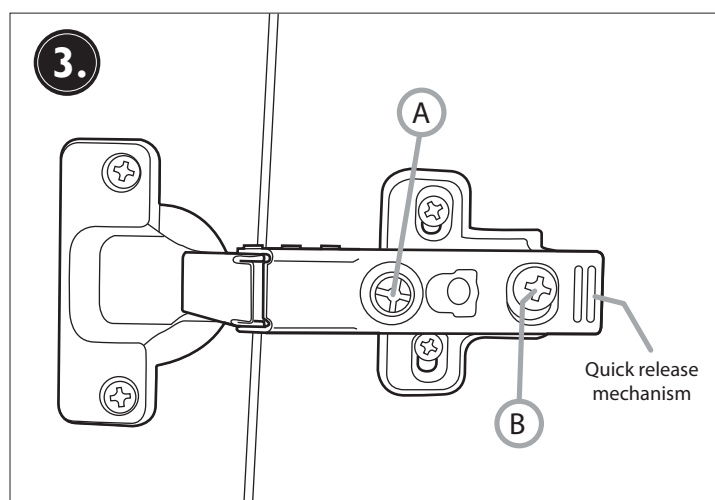
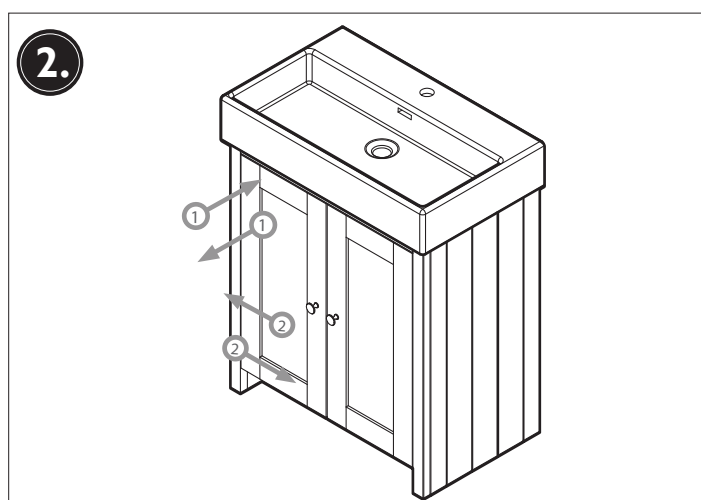

To make adjustment 1 tighten/loosen adjustment B.  
To make adjustment 2 simply turn screw A.

# 550 & 700 VANITY UNITS

## INSTALLATION & AFTERCARE INSTRUCTIONS

### Basin installation

Once the basin has been test fitted and plumbed in, finish by securing the basin to the unit using a silicone sealant (not supplied).

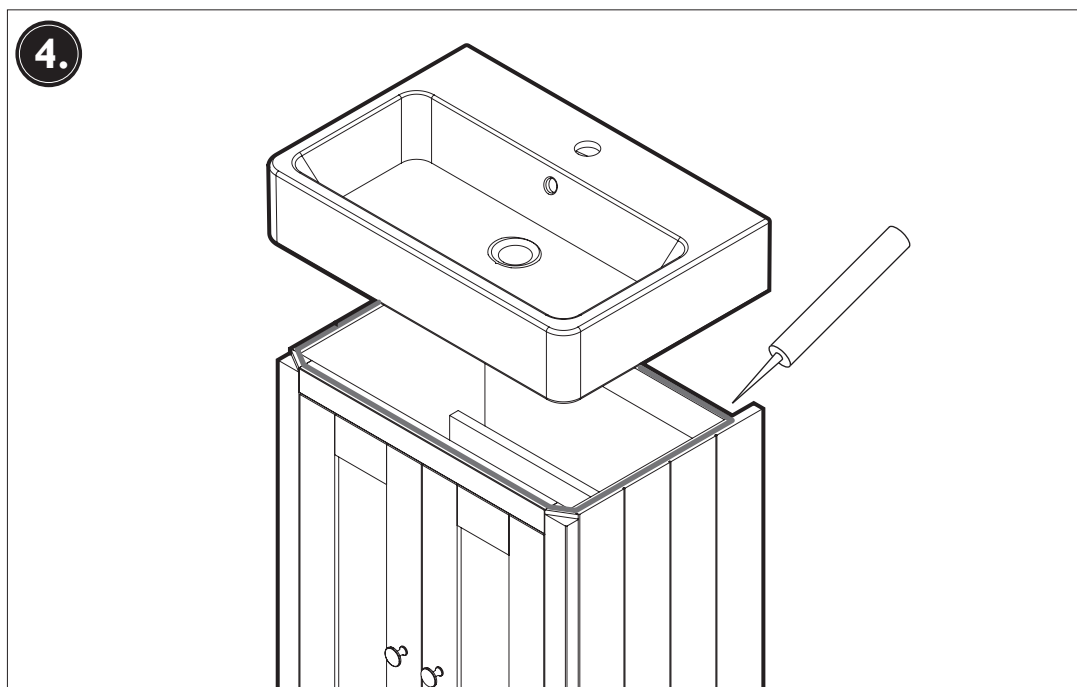

### Furniture Care Instructions

As with all wooden furniture, this product should be treated with care.

#### We recommend...

Wipe away any water splashes or condensation after use.  
Excessive exposure to water will deteriorate the furniture.

All bathrooms should be well ventilated with a suitable extractor fan.

To remove dirt or fingerprints, clean with a soft damp cloth and mild soapy water. Ensure this is dried immediately.

Use a wax free polish if one must be used.

For removal of lime scale deposits use a suitable proprietary cleaner. If necessary test on an inconspicuous area first.

#### Please DO NOT...

Do not scrub or scour.

Do not use abrasive cleaning agents.